

TOSHIBA

S t a t i c **V** a r **C** o m p e n s a t o r

SVC

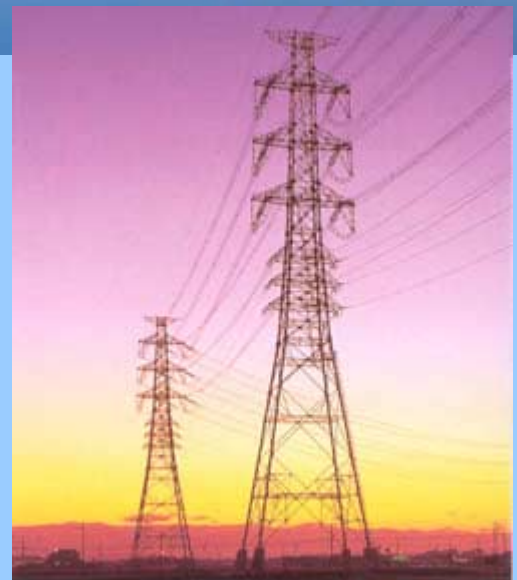
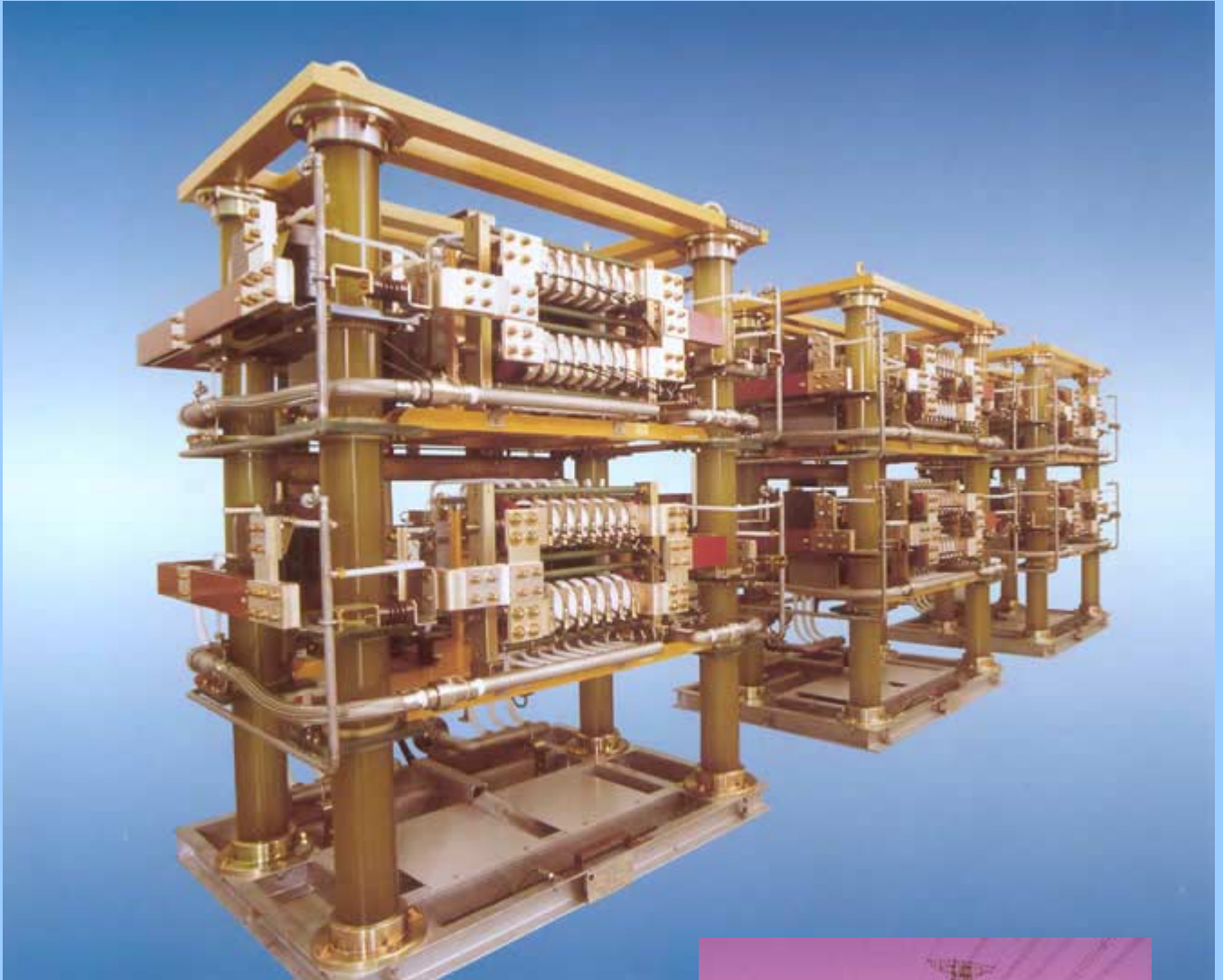

TOSHIBA SVC Compensator

Static Var

TOSHIBA provides SVC system with superior features;

- OPTIMIZED SVC SYSTEM DESIGN
- HIGH QUALITY AND RELIABILITY
- EASY MAINTENAMNCE
- LIGHT TRIGGERED THYRISTOR
- FLEXIBLE DIGITAL CONTROLLER

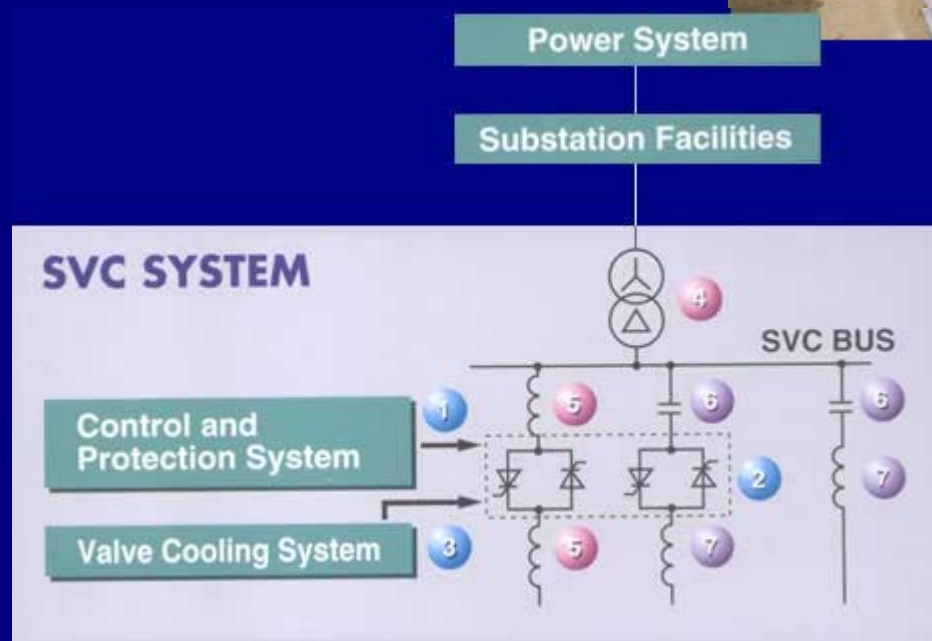
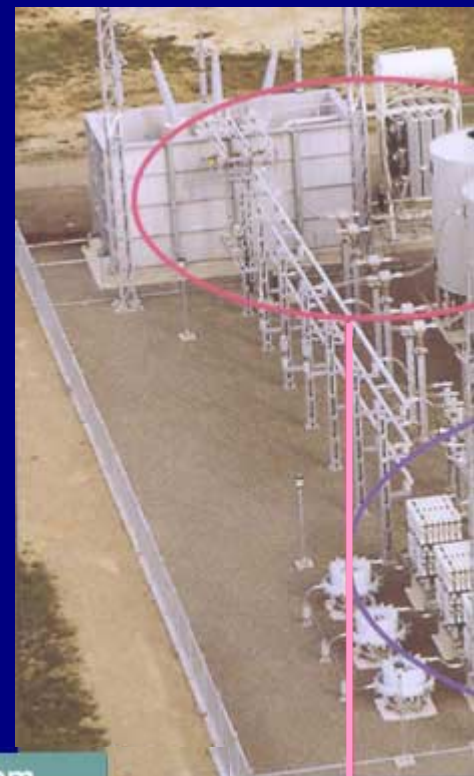

1 Control and Protection System



2 Thyristor Valve



3

Valve Cooling System



4 SVC Transformer

5 TCR Reactor



6 Capacitor Bank

7 Filter Reactor



General Performance

It is essential to balance the supply and demand of active and reactive power in an electrical power system. If the balance is lost, the system frequency and voltage excursion may occur resulting, in the worst case, in the collapse of the power system. Appropriate voltage and reactive power control is one of the most important factors for stable power system operation. Static Var Compensator (SVC) is one of the advanced power electronics equipment, which provides fast and continuous capacitive and inductive reactive power supply to the power system.

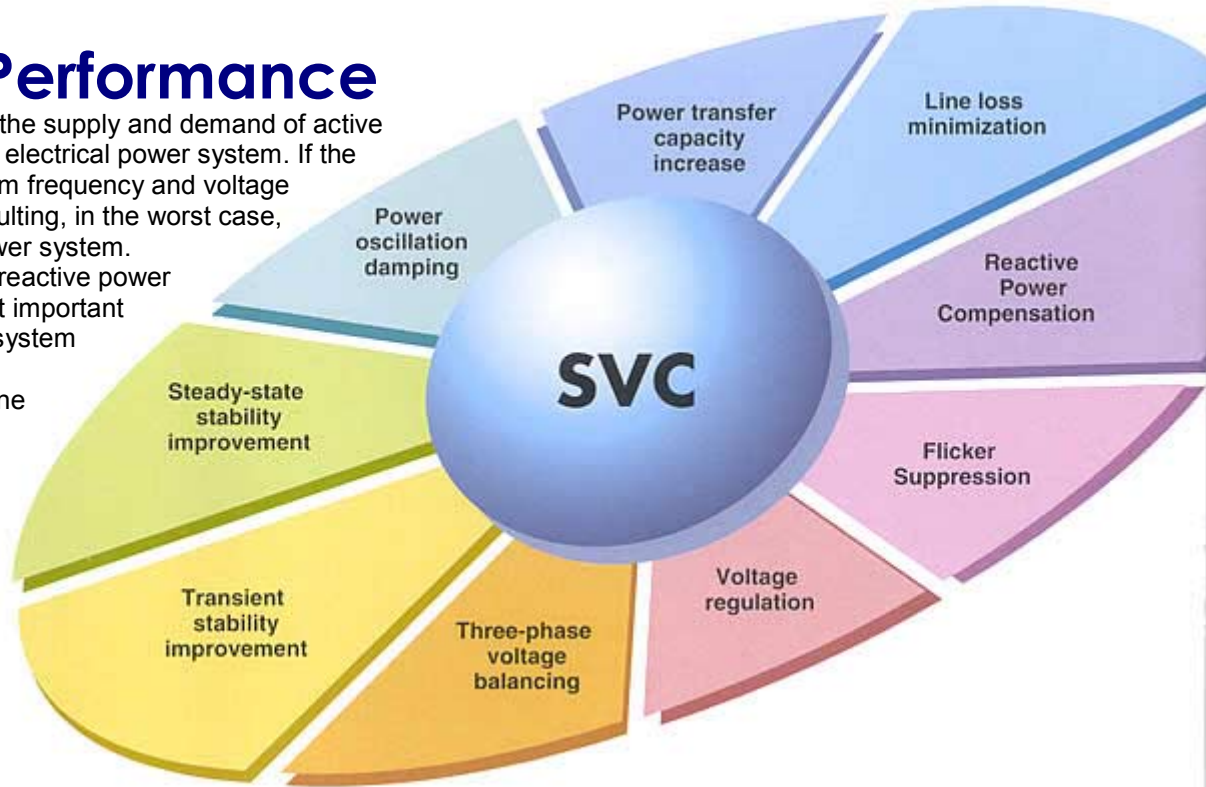

Typical configurations

The SVC typically consist of a TCR (Thyristor Controlled Reactor), a TSC (Thyristor Switched Capacitor) and AC Filters (ACF) as shown in Fig.1. The TCR consist of reactors and thyristor valves. The TCR continuously controls reactive power by varying the current amplitude flowing through the reactors. The TSC consist of capacitors, reactors and thyristor valves. The TSC switches on and off the capacitors. The AC filters provide fixed reactive power and absorb the harmonic current generated by TCR. The TCR+ACF is the most basic configuration of the SVC.

The TCR+TSC+ACF, the more advanced configuration, can be tuned to minimize the losses at the most frequent operation point.

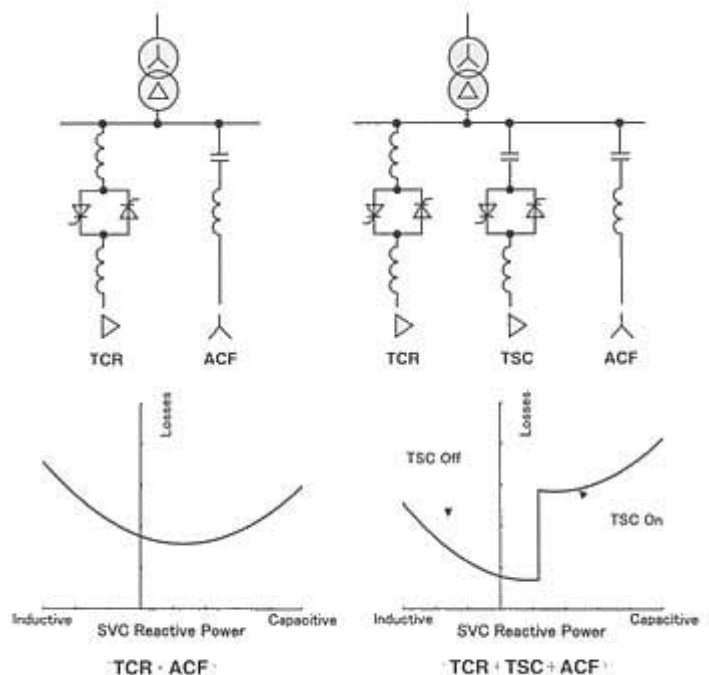
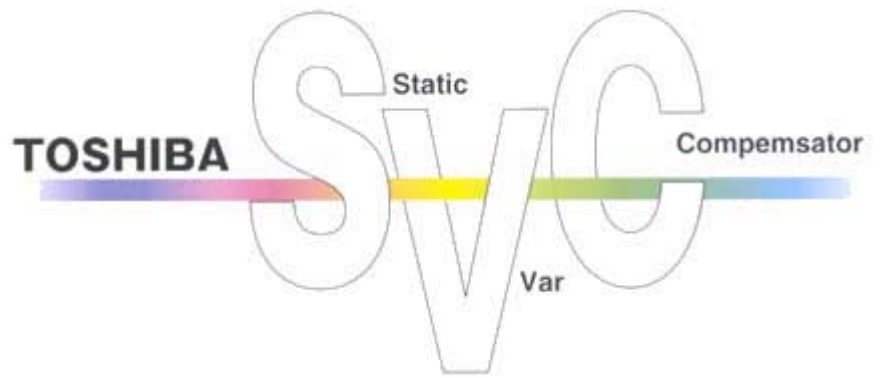

Figure 1 Typical Configuration of SVC



Operation principle

TCR (Thyristor Controlled Reactor)

The amplitude of the TCR current can be changed continuously by varying the thyristor firing angle (Fig2). The firing angle can be from 90 degrees to 180 degrees. The TCR firing angle can be fully changed within one cycle of the fundamental frequency, thus providing smooth and fast control of reactive power supply to the system.

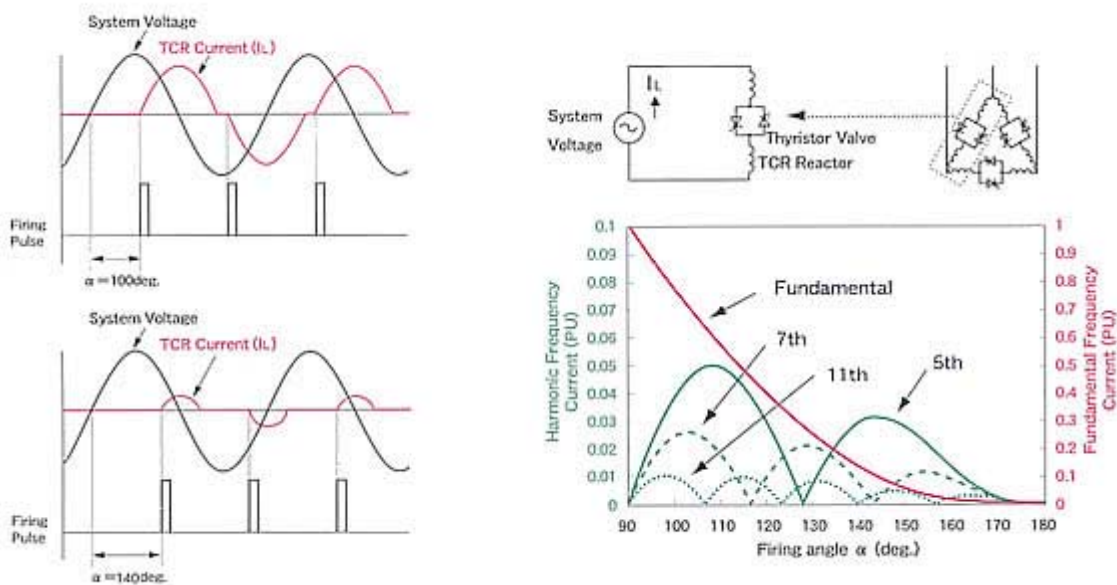

Figure 2 TCR Current and firing angle

TSC (Thyristor Switched Capacitor)

The TSC is used to switch on and off the capacitor. The TSC does not generate any harmonic current components. The capacitor switching operation is completed within one cycle of the fundamental frequency. The TSC provides a faster and more reliable solution to capacitor switching than conventional mechanical switching devices (Fig3).

The TSC can operate in coordination with TCR so that the sum of the reactive power from the TSC and the TCR becomes linear. Applications with only TSC's are also available, providing stepwise control of capacitive reactive power.

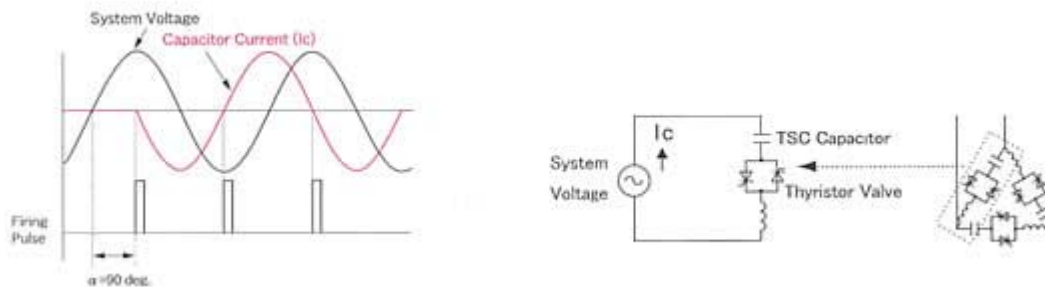

Figure 3 TSC Current and firing angle

AFC (AC Filter)

AC filters are used to reduce the harmonics injected into the power system by TCR operation. AC filters also provide a certain amount of capacitive reactive power.

SVC System Engineering

Toshiba designs SVC systems utilizing best engineering practice and previous vast experience. Toshiba can provide all of the studies necessary for the SVC system design and offer the best solution to customers.

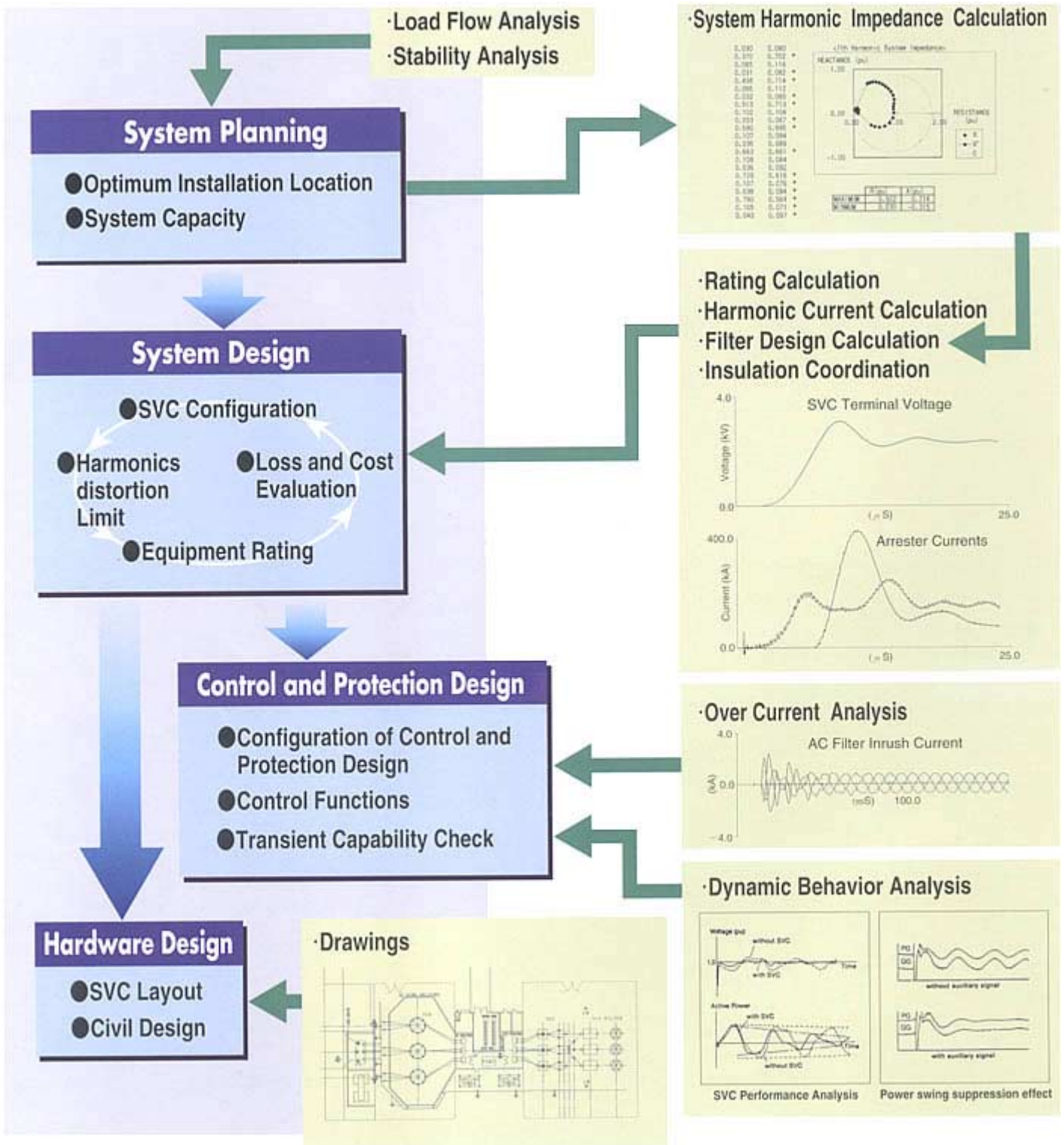

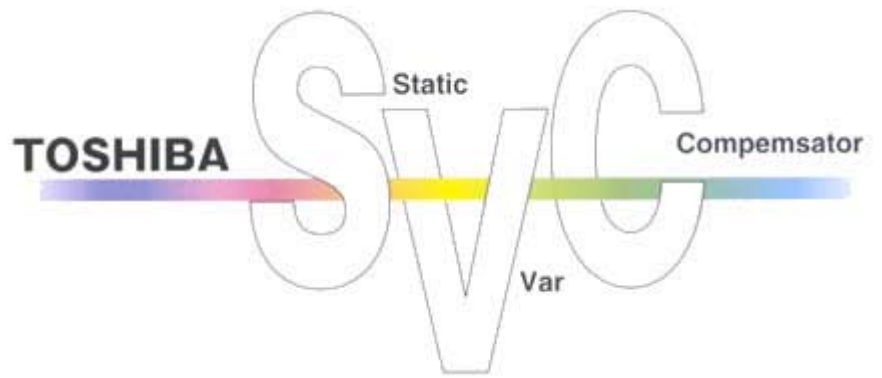

Flexible Digital Control System

Toshiba provides a digital controller as part of the SVC system. The digital controller utilizes multiple 32 bits CPU and high precision Digital signal processor (DSP) to control the thyristor valves in both the TCR and TSC. The digital control system also controls various other AC system equipment. The all-digital technology offers high flexibility, reliability, simple and easy maintenance.

Easy parameter Adjustment

The controller unit includes a control panel and LCD display. Through the control panel and LCD display engineering personal can read measured values and manipulate the controller parameters. The controller can also be accessed remotely, through a communication port.



Reliable Software Configuration

All of the control functions are implemented through the software installed in the controller. The controller software is easily modified with the specialized development tool. This software development tool (PE-CASE) consists of the Windows based control block diagram drawing function and automatic software code generation function. The control block diagram drawn on a personal computer running Windows operating system can be automatically coded in to object files and loaded into the CPU or the DSP without software error. Toshiba provides the PE-CASE control software development tool and the training course as part of the SVC controller package to enable the customer to do future control system and parameter modifications.



Power System Simulator

Toshiba has a sophisticated power system simulator, which enable real-time, high precision dynamic simulation of large power system. Upon request, the SVC controller performance can be examined in detail using the simulator.

Digital simulators are also available and are recommended for reduced scale power system.

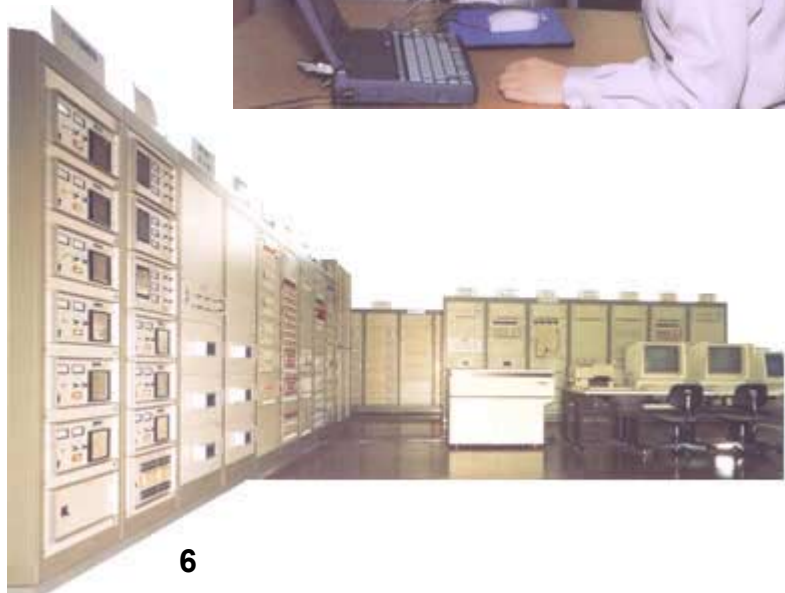

Direct Light Triggered Thyristor Valve

Toshiba pioneered direct Light Triggered Thyristor (LTT) application to high power electronic valve. The first commercial installation of a LTT valve for SVC was completed in 1984. Since then, Toshiba has provided LTT valves for numerous facilities through the world.

ETT Valve

ETT; Electrically Triggered Thyristor
 AMP; Gate electronics
 PC; Power Circuit
 L/E; Light/Electric Converter
 LG; Light Guide
 LED; Light Emitting Diode
 PG; Pulse Generator
 L; Reactor
 R1, C1, R2; Voltage Grading Circuit

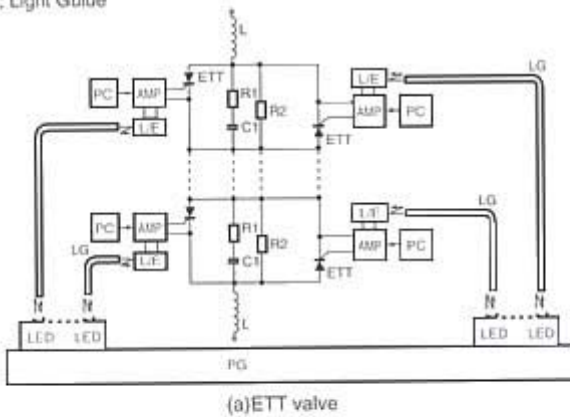

(a)ETT valve

< Conventional EET System >

LTT Valve

LTT; Light Triggered Thyristor
 LG; Light Guide
 LED; Light Emitting Diode
 PG; Pulse Generator
 L; Reactor
 R1, C1, R2; Voltage Grading Circuit

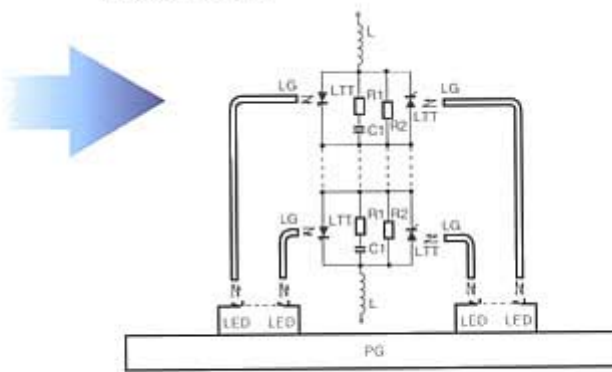

(b)LTT valve

< Applied LTT System >

Reduction Number of Parts

The conventional Electrically Triggered Thyristor (ETT) requires complicated electronic circuits in the triggering system. The thyristor triggering electronic circuits require a large number of parts for each thyristor valve. Thyristor triggering circuitry has to be insulated to the valve voltage in relation to ground potential. Contrary to the ETT, the LTT can be fired directly through the optical fibers requiring less complicated triggering circuitry and no high voltage insulation (Fig4).

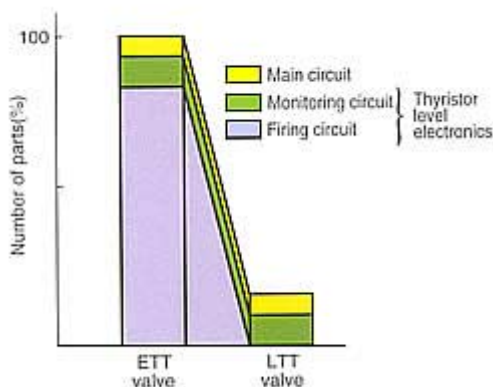

Figure 4 Number of parts in a valve

Reliability Improvement

The reduction in number of parts results in higher reliability of the valve (Fig5). LTT valves have reliability twice that of the ETT valves.

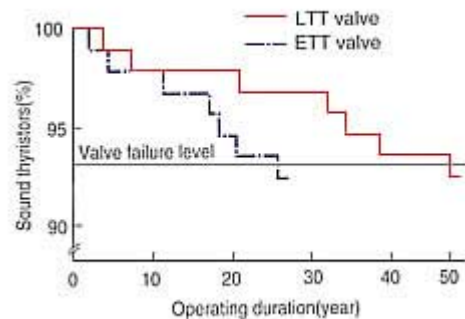
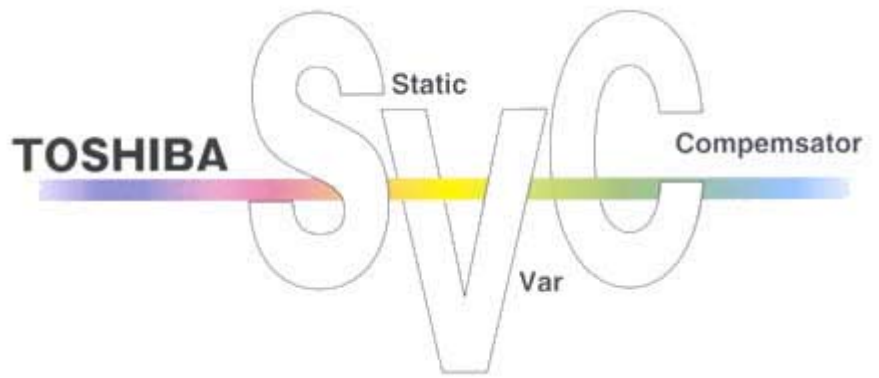

Figure 5 Reliability Comparison of valves



Easy maintenance

The elimination of gate electronics circuitry offers great advantages in maintenance. Since no complicated electronic circuitry is located at the thyristor level, the maintenance becomes very simple and is reduced to the inspection of a small number of parts in the thyristor valve.

A comparison in valve maintenance time and cost between ETT and LTT is shown below.



Item	ETT	LTT
Inspection parts	100%	Approx. 30%
Maintenance time	100%	Approx. 30%
Maintenance interval	100%	Approx. 200%
Maintenance cost	100%	Approx. 15%

Operation Flexibility Improvement

The power for triggering of the LTT valve is provided from the DC power supply. The LTT valve operation is therefore not affected during prolonged power system faults.

Contrary to the LTT, the ETT valve requires auxiliary power to generate firing signal at the thyristor level. The Auxiliary power is usually obtained from the voltage across the thyristor element. The ETT valve operation is therefore restricted at the SVC start up and during prolonged power system faults.

Electromagnetic Noise immunity improvement

Optical signals used for triggering of the LTT valve have inherent immunity to electromagnetic noise. In contrast, the ETT valve requires countermeasures against electromagnetic noise.

Reliable Firing System

The optical triggering system is based on the branched light guides and duplicated LED. Two high power triggering LED's are connected to each LTT. In the event of a failure of one of the two LED's, the LTT can be triggered by the remaining LED.

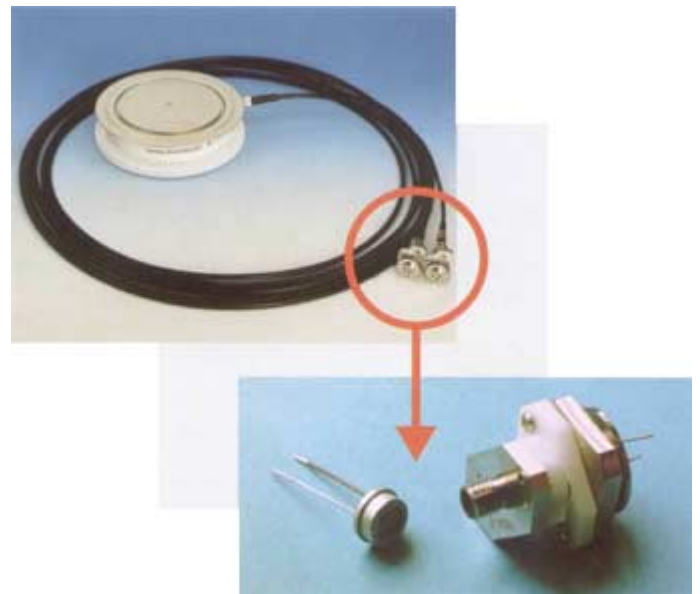

Valve Cooling System

Excess heat generated in thyristor valve is removed by the cooling system. Due to the high efficiency, the water cooling system (Figure 6) is applied to large capacity valves. The forced air cooling system is applied to small capacity valves. Toshiba has installed cooling system for SVC valves in many different environments.

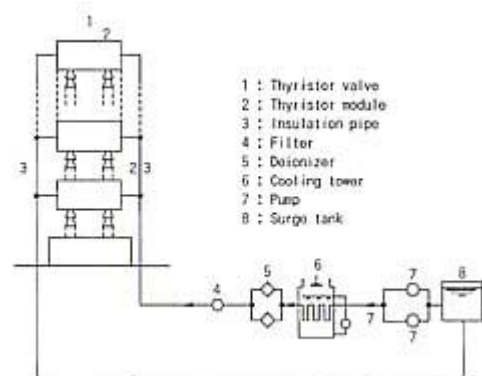

Figure 6 Valve (Water) Cooling System

Water cooling system has following advantages;

- Compact design
- Maximization of thyristor current capability
- Small auxiliary losses

Other Equipment

Transformer

A step-down transformer is usually placed between the AC system bus-bar and the low voltage bus-bar to which the thyristor valves are connected. Once the SVC capacity is determined, the best way to design the valve is to use the thyristor current capability at its maximum. Then the minimum necessary AC voltage is derived to obtain the given capacity. The AC voltage across the thyristor valve determines the number of thyristor in the valve and consequently the valve cost. The step-down transformer adjusts the AC voltage for the minimum system cost. The transformer increases the thyristor valve efficiency.



TCR Reactor

The TCR reactor generates inductive reactive power of the SVC. Air core reactors are most commonly applied. The inductance value of the reactors is custom designed for each system in order to satisfy the specified reactive power output.

AC Filter Bank

AC filter banks provide capacitive reactive power and absorb the harmonic currents generated by the TCR. The AC filter banks are carefully designed considering the harmonics environment in the AC system. Usually, oil filled capacitors with fuse and air core reactors are applied.



Switchgear

The switchgear is necessary to connect or disconnect the SVC to or from the AC system. Toshiba is one of the major suppliers of both gas and air insulated switchgear.

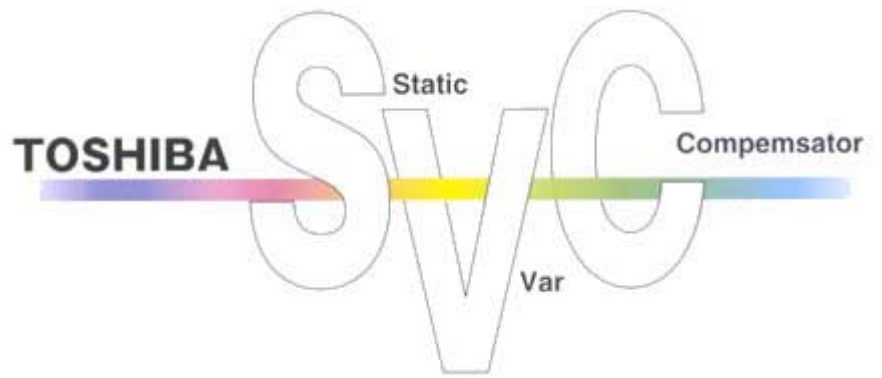

Quality Control System

As a Japanese manufacturer famous worldwide for their high quality, Toshiba established an effective quality control system. The quality control system has been proven to comply with the requirement of the ISO 9000 standards.



System Design and Engineering
Optimum SVC System is designed for each project.



Manufacturing



Factory tests
Valve and controller are fully tested.



Site Tests
Performance tests are carried out combining
● all controllers and protection devices and
● all AC and DC auxiliary equipment.

Approval of ISO9001/ISO14001

Toshiba was one of the first companies to conform to ISO9001, an international standard for quality assurance.

To further improve reliability and protect the environment, Toshiba continues to utilize leading edge technology and facilities to maximize quality and efficiency, and to meet the requirements of environmental standards ISO14001.

Caring for and protecting the global environment, guided by the motto "creating a Human and Earth friendly Environment", Toshiba is engaged in a wide range of activities to minimize the use of chemical substances and to save energy.

TOSHIBA STATCOM

Toshiba is a pioneer of the self-commutated semiconductor device, the Gate Turn-Off thyristor (GTO). Utilizing the GTO thyristor technology, Toshiba has many experience on STATCOM than the other companies.

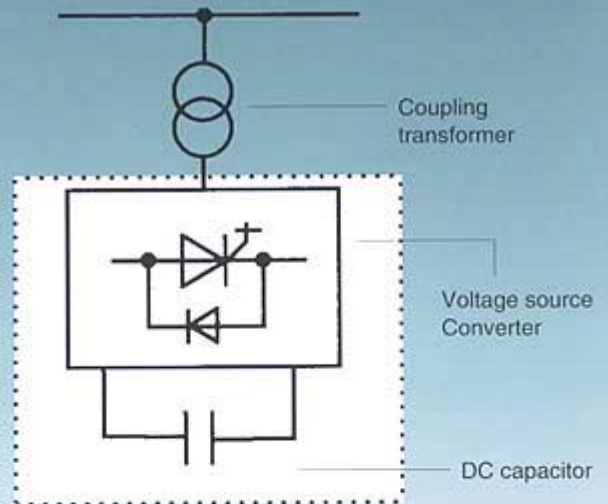

STATCOM is the Voltage Source Self-Commutated Converter, consisting of the inverter bridge, the DC capacitor and the coupling transformer.



The STATCOM offers following advantages;

- Superior voltage supporting capability
 - Fast
 - Large reactive power generation under low system voltage condition
- Less harmonics generation
- Smaller filter capacity
- Less space requirement

Operation principle of the STATCOM

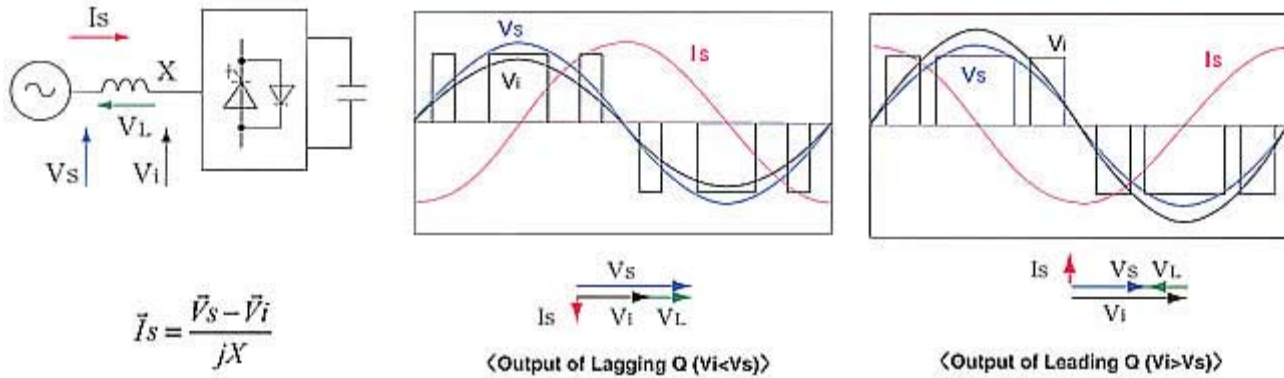

The reactive power control is fast and continuous from inductive to capacitive through the adjustment of the inverter AC voltage output.

IEGT, the Next to Come

Based on the vast experience in STATCOM system design and supply using GTO devices, Toshiba has developed a more advanced semiconductor device, the Injection Enhanced Gate Transistor (IEGT).

The IEGT has high power ratings comparable to the GTO and can be operated at high speed comparable to the Insulated Gate Bipolar Transistor (IGBT).

The IEGT is the voltage driven device and needs a small amount of power for triggering. The number of gate circuit parts and the size of snubber circuits are dramatically reduced in comparison with the GTO technology. The IEGT valve will offer compact and cost-efficient converters for SVC systems.

IEGT has following features;

- Low losses with smaller snubber circuit
- Low gate power based on voltage driven MOS (Metal Oxide Semiconductor) gate
- Fast switching speed



Outside View of IEGT

FWD chips are included in the IEGT shell.

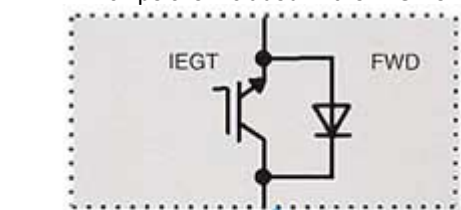

FWD : Free Wheeling Diode

VARIOUS APPLICATIONS



**275kV, 230MVA SVC,
Queensland Australia**
-80MVA (inductive) to
+150MVA (capacitive)
consists of TCR+FC

Voltage Control

regulates and controls the 275kV system voltage at the set point under steady state and contingency conditions.

**275kV, 300MVA SVC,
South Australia**
-140MVA (inductive) to
+160MVA (capacitive)
consists of TCR+TSC

Power Oscillation Damping

regulates the 275kV bus voltage, improves the system stability and damps the power oscillation.



**400kV, 580MVA SVC,
Austria**
-580MVA (500ms) (inductive)
consists of TCR

Overvoltage Suppression

suppresses overvoltages generated at the HVDC converter load rejection.

TOSHIBA has supplied various types of SVC and STATCOM systems custom designed for specific installation conditions and requirements. Some of different designs and applications are shown.



**500kV, 100MVA SVC,
Tokyo Japan**
-20MVA (inductive) to
+80MVA (capacitive)
consist of TCR+FC

Voltage Stabilization

stabilizes 500kV voltage on a major power transmission system.

**500kV, 50MVA
STATCOM**

Nagano Japan

A large capacity STATCOM of 50MVA had been operated successfully since October 1992 at Shin-Shinano Substation in Japan.



**-40MVA (inductive) SVC,
Osaka Japan**

Relocatable SVC

A relocatable SVC is transported by a trailer to the installation site.



TOSHIBA

TOSHIBA CORPORATION
POWER SYSTEM & SERVICES COMPANY

1-1, SHIBAURA 1-CHOME, MINATO-KU, TOKYO 105-8001, JAPAN
TEL (03)3457-3782 FAX (03)5444-9184