

TOSHIBA

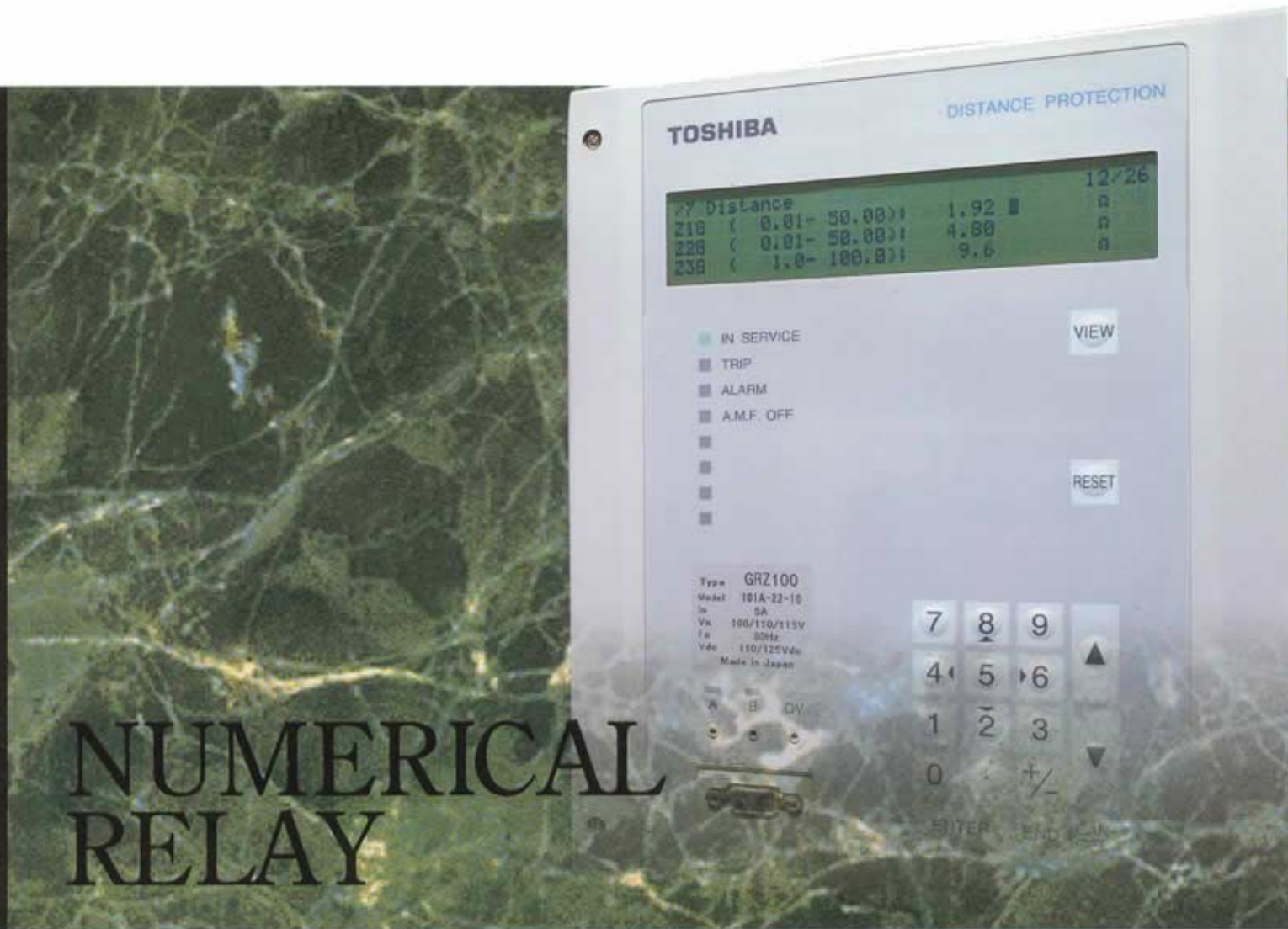

**NUMERICAL
RELAY**

GRZ100
DISTANCE RELAY



Relay case Type-A



Relay case Type-B

FEATURES

- Fully numerical distance protection relay
- High speed operation typically 20ms
- Time-stepped distance protection
- Zone 1 extension protection
- Command protection (distance protection using telecommunication) with weak end infeed logic
- Command protection with directional earth fault (DEF) over current relay
- High-resistance earth fault protection
- Broken conductor detection
- Overcurrent backup protection
- Switch-on-to-fault and stub protection
- Breaker failure protection
- Out-of-step trip protection
- Power swing blocking
- Single-shot or multi-shot autoreclose
- Fault location
- Configurable binary outputs
- Automatic supervision
- Metering and recording functions
- Menu-driven human interfaces
- Two serial ports for a local PC and a remote PC
- IRIG-B port for external clock

APPLICATION

GRZ100 is a full-scheme high-speed numerical distance relay for application to transmission lines in solidly earthed networks. The relay can be interrogated using a local PC or a remote PC through the communication ports. GRZ100 provides the following protection schemes.

- Time-stepped distance protection
- Zone 1 extension protection
- Command protection (distance protection using telecommunication)
- Overcurrent protection for SOTF and stub fault .Out-of-step protection
- Breaker failure protection

As a backup protection for high-resistance earth faults, GRZ100 provides the following four functions.

- Directional earth fault protection
- Directional earth fault protection using telecommunication
- Directional or non-directional inverse time over current and earth fault protection
- Definite time over current and earth fault protection

GRZ100 can initiate high-speed single-shot autoreclose or multi-shot autoreclose.

GRZ100 provides the following metering and recording functions.

- Metering
- Fault recording
- Event recording
- Fault location
- Disturbance recording

GRZ100 provides the following human interfaces for relay setting or viewing of stored data.

- Relay front panel: LCD, LED display and operation keys
- Local PC
- Remote PC

The relay can be accessed from a local PC or a remote PC through communication ports.

A local PC can be connected to the relay via the RS232C port on the front fascia of the relay and a remote PC can also be connected to the relay through the RS485 port at the rear of the relay.

GRZ100 has five models which differ depending on whether or not the autoreclose or fault detector functions have been included.

Model 100	-No autoreclose -No fault detector
Model 200	-With auto close for single breaker scheme -No fault detector
Model 300	-With auto close for one-and-a half breaker scheme
Model 400	-With auto close for single breaker scheme -With fault detector
Model 500	-With auto close for one-and-a-half breaker scheme -With fault detector

Model 100 series is not equipped with the autoreclose and fault detector functions.

Models 200 through 500 series have the autoreclose function.

Model 200 series has a single- and multi-shot autoreclose function and is applied for single breaker autoreclose scheme. Model 300 series has a single-shot autoreclose function and can be applied for one-and-a-half breaker autoreclose schemes. Additional security can be provided in Models 400 and 500 series which have an independent fault detector in the form of a check relay, against non-power system fault tripping. Model 400 series is used for single breaker autoreclose schemes and Model 500 series for one-and-a-half breaker schemes.

RELAY FUNCTIONS

■ Time-Stepped Distance Protection

GRZ100 provides three-step distance protection for forward faults and one additional protection for reverse faults. GRZ100 is a full scheme relay and provides individual phase fault measuring elements and earth-fault measuring elements for all types of fault for Zones 1 to 4 as shown in Figures 1 and 2.

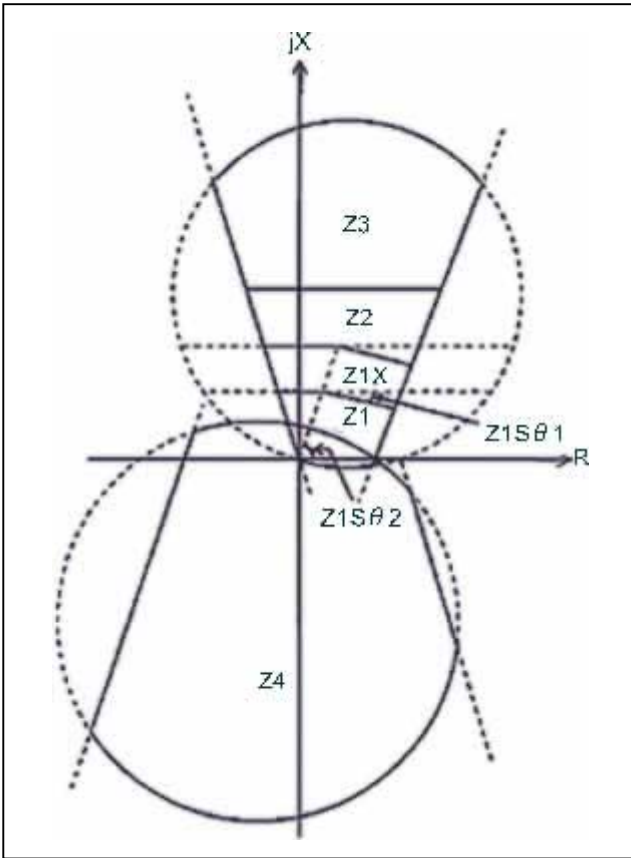

▲ Fig. 1 phase fault measuring element

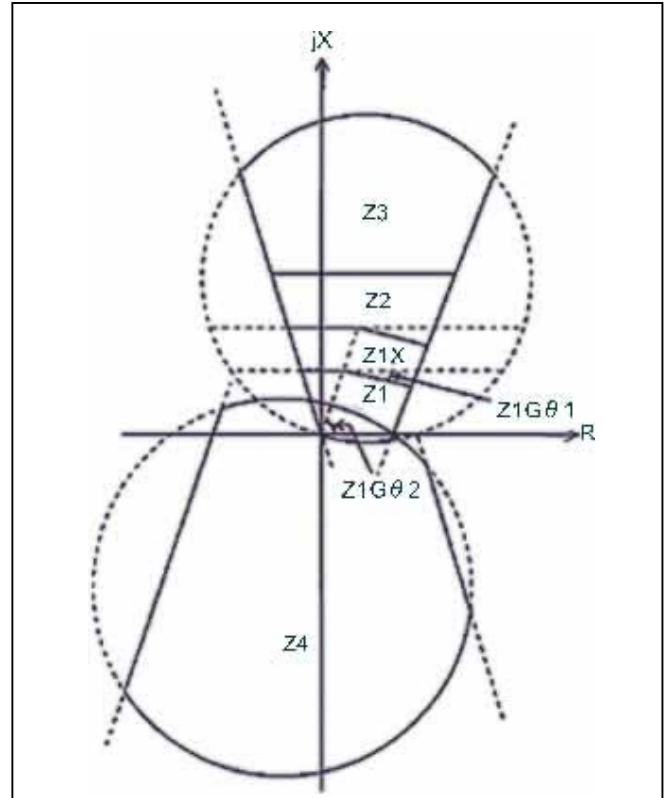

▲ Fig. 2 Earth fault measuring element

Zone 1 consists of mho, blinder, and reactance elements. The tripping mode of Zone 1 can be selected for instantaneous or time delayed tripping.

The reactance line of Zone 1 can take a negative gradient when the terminal is sending loads, which prevents Zone 1 from overreaching for remote end faults.

To ensure time-delayed tripping for close-up three-phase faults, the phase fault mho elements are reverse offset following Zone 1 operation.

Zone 2 consists of mho, blinder, and reactance elements. Zone 2 provides protection for the rest of the protected line not covered by Zone 1 and backup protection for the remote end busbar.

Zone 3 consists of mho and blinder elements. Zone 3 provides remote back-up protection for adjacent lines.

Zone 4 consists of reverse looking mho and blinder elements. Zone 4 is used for local back-up protection for busbar faults or transformer faults.

Zone 4 phase-fault elements have an offset characteristic in order to detect reverse close-up phase faults.

On long-distance or heavily loaded lines, the load impedance may encroach on the operating zone of mho elements. To avoid operation of the mho elements in the load impedance area, blinder elements are incorporated.

■ Zone 1 Extension

When telecommunications cannot be applied, a Zone 1 extension protection is provided for high-speed protection of any fault along the whole length of the protected line.

Zone 1 extension (Zone 1X) consists of mho, blinder, and reactance elements.

The reactance line of Zone 1 extension can take a negative gradient when the terminal is sending loads, which prevents Zone 1 extension from overreaching.

■ Distance Protection using Telecommunication

The following four schemes are available for distance protection using telecommunication.

Permissive Under reach Protection (PUP)

- Permissive Overreach Protection (POP)
- Unblocking Overreach Protection (UOP)
- Blocking Overreach Protection (BOP)

POP and UOP are equipped with echo logic and weak infeed tripping functions and can be used in the protection of lines with weak infeed or no infeed terminals. An under voltage element is incorporated for the weak infeed tripping function.

■ Earth Return and Mutual Coupling Compensation

Zone 1, Zone 2 and Zone 1 X for earth fault protection adopt vectorial zero sequence current compensation to eliminate distance measuring errors due to the earth return of zero sequence current. When the GRZ100 is applied to a double circuit line, in order to eliminate the affect of zero sequence mutual coupling, the zero sequence current for the parallel line can be introduced.

■ Fault Phase Selection

GRZ100 provides single- and/or three-phase tripping functions.

In order to perform extremely reliable single-phase tripping, an under voltage element with current compensation is used for phase selection.

The under voltage element with current compensation can operate correctly even for a fault with a strong power source and small voltage drop at the relay installation point.

The characteristics of phase selection element are as shown in Figure 3.

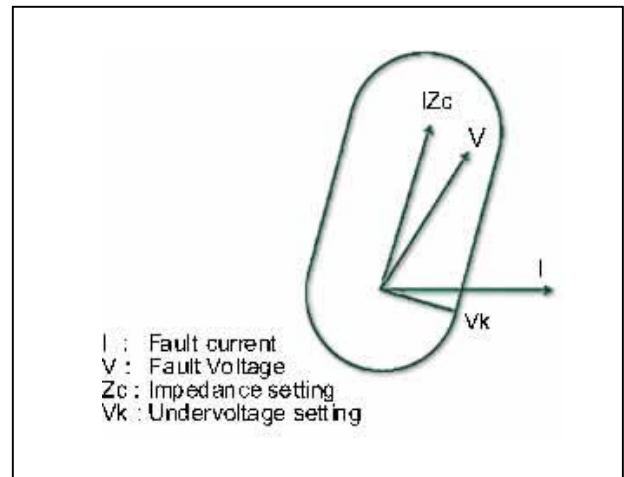

▲ Fig. 3 Phase selection element

■ Switch-on-to-fault Protection and Stub Protection

Switch-on-to-fault (SOTF) protection is provided in order to detect that are present when a line or busbar is energized.

For 500ms following circuit breaker closure, this function is effective to protect against any switch-on-to-fault. A no directional over current element or distance measuring elements perform the SOTF protection.

Stub protection operates for a fault in a stub zone using the over current element.

■ Broken Conductor detection

Earth fault over current element that detects current unbalanced condition can detect and alarms the broken conductor.

■ Voltage Transformer Failure Supervision

Failure in the voltage transformer (VT) secondary circuit may cause false tripping by voltage dependent measuring elements. Therefore, the following voltage dependent protections are blocked instantaneously when VT failure is detected.

- Zone 1 through Zone 4 distance protection
- Directional earth fault protection
- Protection using telecommunications
- Out-of-step protection

VT failure is detected in any of the following cases.

- If residual voltage is detected when residual current is not detected
- If under voltage is detected when a current change is not detected

■ Power Swing Blocking

The relay provides a power swing blocking (PSB) function to prevent false tripping by distance measuring elements during power swing.

When a power swing is detected, distance protection of Zones 1 to 3, Zone 1 extension protection and protection using telecommunication can be blocked independently.

To detect a power swing during single-phase autoreclosing, GRZ100 provides three individual phase-to-phase power swing blocking detectors.

A power swing condition is detected using two PSB elements with quadrilateral characteristics. The outer PSB element encloses the inner element with the width of PSBZ.

If the impedance locus enters PSBZ zone for more than a predetermined time (20 to 60ms), the PSB function will block the selected zones. The PSB function is reset after 500ms when the impedance locus has moved outside the PSB elements.

GRZ100 can provide a high-speed protection for faults which occur during a power swing by using any of the command scheme.

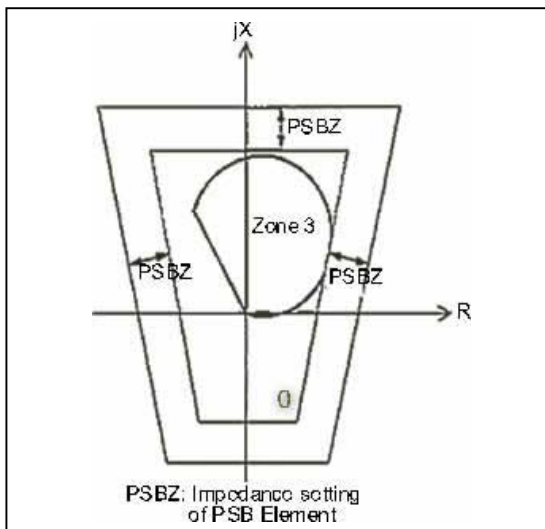

▲ Fig. 4 Characteristic of power swing blocking element

■ Out-of-Step Protection

The out-of-step tripping function is used for power system separation at the optimum point when an out-of-step occurs.

An out-of-step is detected by using two distance measuring elements with quadrilateral characteristics as shown in Figure 5. The element operates when the out-of-step locus passes from Zone A → Zone B → Zone C (or Zone C → Zone B → Zone A) and remains in Zones A and C for the detection time (TOST).

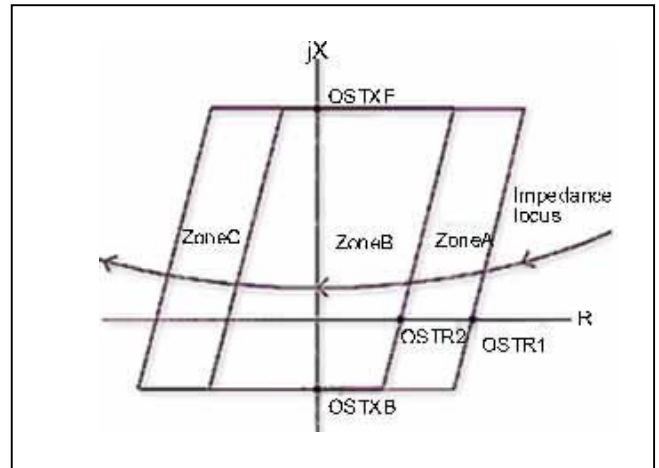

▲ Fig. 5 characteristic of out-of-step element

■ Breaker Failure Protection

When an over current element remains in operation longer than a predetermined length of time following the output of a trip signal the associated circuit breaker is judged to have failed and adjacent circuit breakers can be tripped as a back-up measure.

Two independent timers are available, one of which can be used to control the RETRIP of the original circuit breaker(s). The second timer being used to control the back tripping of adjacent circuit breakers.

For high-speed protection, an over current element with high speed reset time is used to prevent a spurious re-trip or back trip following a successful trip or retrip action.

■ Overcurrent Backup Protection

■ Inverse time over current protection

The IDMT (inverse definite minimum time) over current element is provided for non-directional inverse time over current protection. The IDMT element is available in conformity with either of three IEC Standard characteristics (Standard inverse, Very inverse, and Extremely inverse) or a Long-time inverse.

The characteristics of each IDMT are shown in Figure 7.

■ Definite time over current protection

Definite time over current protection is enabled by the instantaneous over current element and pickup-delay timer.

■ High-resistance Earth Fault Protection

This protection provides high-resistance earth fault protection using the directional earth fault (DEF) element and the earth fault over current element as follows.

■ Directional earth fault protection

DEF element is used for time-delayed backup protection for high resistance faults.

■ Directional earth fault protection using telecommunication

High-speed DEF protection using telecommunications is provided by using a forward looking DEF element and a reverse looking DEF element. POP, UOP, and BOP schemes can be selected with DEF protection using telecommunications.

The characteristics of the forward and reverse looking DEF elements are as shown in Figure 6.

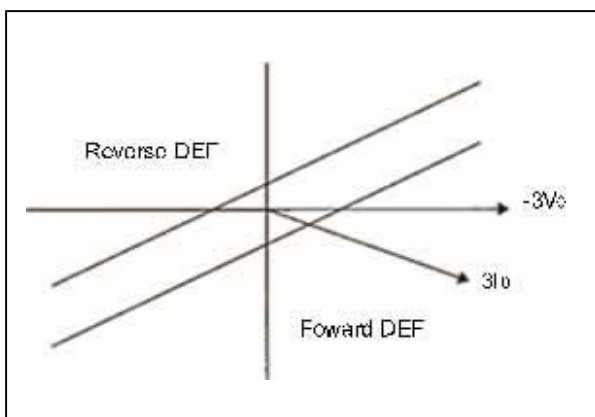

▲ Fig. 6 Characteristic of directional earth fault element

■ Inverse time over current earth fault protection

Directional or non-directional inverse time over current earth fault protection is provided using a combination of the IDMT (inverse definite minimum time) over current earth fault element and DEF element. The IDMT element is available in conformity with either of three IEC Standard characteristics (Standard inverse, Very inverse, and Extremely inverse) or a Long-time inverse.

The characteristics of each IDMT are shown in Figure 7.

■ Definite time over current earth fault protection

Definite time over current earth fault protection is provided using the instantaneous over current element and pickup-delay timer.

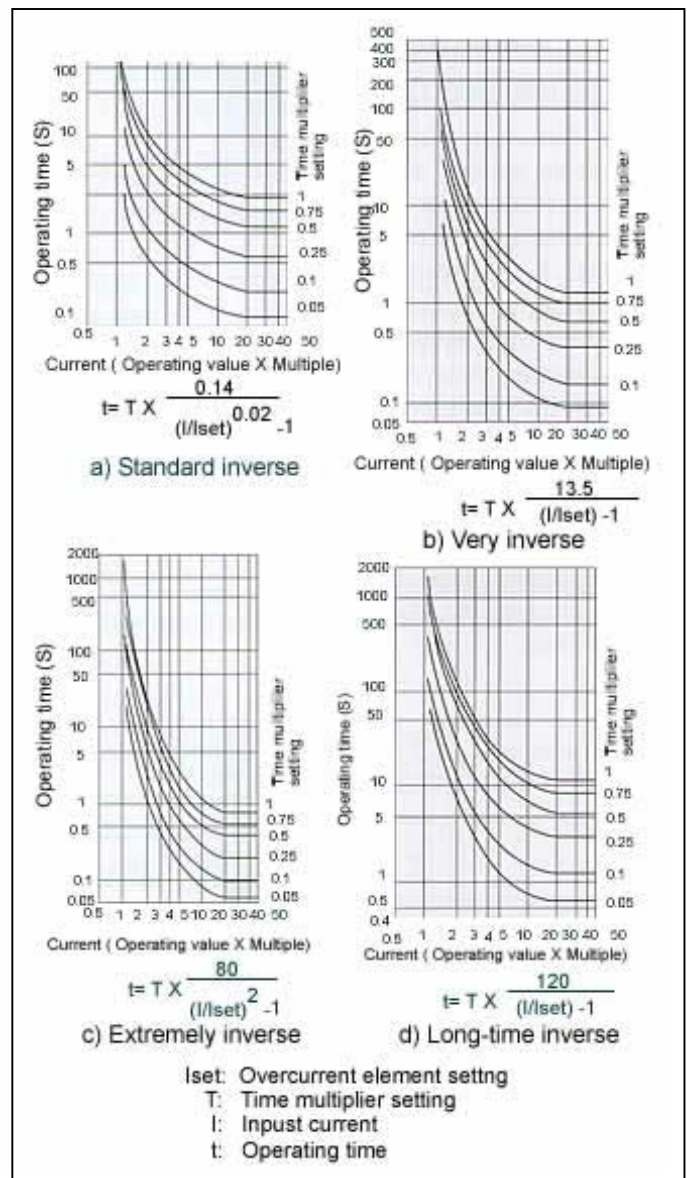

▲ Fig. 7 IDMT operating time characteristics

■ Autoreclose

The GRZ100 autoreclose function can be initiated by any of the following high speed protections.

- Protection using telecommunication
- Zone 1 extension protection

■ Single-and multi-shot autoreclose (Models 200 through 500)

GRZ100 provides two autoreclose systems, single-shot autoreclose and multi-shot autoreclose.

Single-shot reclosing can select any of three autoreclose modes; single-phase autoreclose; three-phase autoreclose, and single-and three-phase autoreclose.

In multi-shot autoreclose, two- to four-shot reclosing can be selected. The first shot is selected from any of the three autoreclose modes available in the single-shot autoreclose scheme. If reclosing by the first shot fails, three-phase tripping and reclosing is applied for the second to fourth shots.

■ Synchronism check

For the correct operation of three-phase autoreclose, voltage and synchronism check are necessary. Characteristics of the synchronism check element are shown in Figure 8.

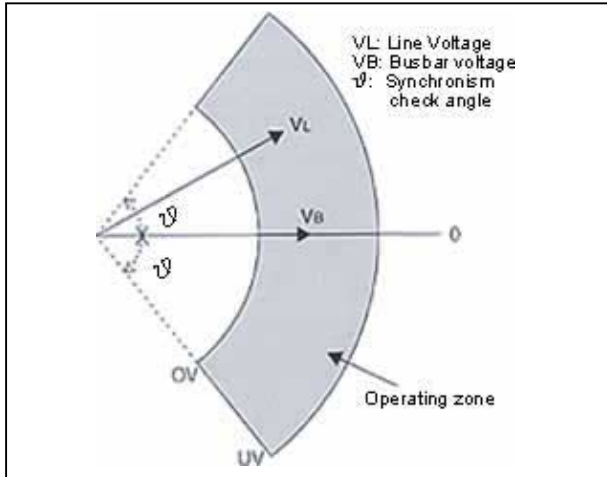

▲ Fig. 8 Synchronism check element

A detected slip cycle is determined by the following equation:

$$f = \frac{\theta}{180^\circ \times T_{syn}}$$

where,

- f: slip cycle
- θ: synchronism check angle setting
- TSYN: synchronism check timer setting

■ One-and-a-half breaker scheme (Model 300, Model 500)

GRZ100 performs two-breaker autoreclose in a one-and-a-half breaker scheme.

Single-shot autoreclose is only available in Models 300 and 500. Single-phase autoreclose, three-phase autoreclose or single and three-phase autoreclose can be applied to the two circuit breakers.

■ Fault Detector (Model 400, Model 500)

GRZ100 can enhance security against non-power system fault tripping by providing a fault detector in the form of a check relay with independent circuits.

The fault detector incorporates the following six fault detection elements.

- Multi-level over current element
- Current change detection element
- Earth fault over current element
- Under voltage element for earth fault detection
- Undervoltage element for phase fault detection
- Undervoltage change detection element

HARDWARE

Figure 9 shows the hardware block diagram of the relay. The relay has a multiple microprocessor design.

The microprocessors perform the software functions such as signal processing, protection algorithm, scheme logic, output relay control and handling of the human interface.

Analog inputs include phase current inputs, residual current inputs and phase voltage inputs.

The number of analog inputs depends on the model of the relay. The internal auxiliary transformers are used to isolate, step down and condition the inputs from the VT and CTs. Their output signals are then converted into digital data for further processing. The front panel contains a 4 x 40 character, liquid crystal display (LCD) and 19 pushbutton keys to provide local access to the relay menu. There are also 8 light emitting diodes (LED) for visual indication of the status of the relay.

The relay provides three communication ports, RS232C for connection of a local PC, RS485 for a remote PC and IRIG-B for an external clock.

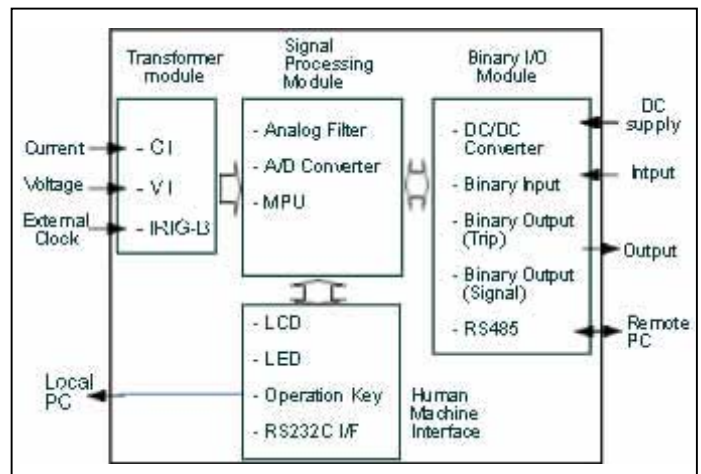

▲ Fig. 9 Hardware block diagram

The terminal blocks are located at the rear of the relay providing connections for all input and output circuits.

The relay is housed in either a type-A or type-B case, suitable for either rack or panel mounting as shown in Figures 23 to 26.

METERING AND RECORDING

■ Metering and Monitoring

The following power system data is measured continuously and displayed on the LCD on the relay fascia, at the local PC, and the remote PC when connected.

- Voltages (phase, phase to phase, symmetrical components)
- Currents (phase, phase to phase, symmetrical components)
- Active power and reactive power
- Frequency

Currents and voltages can be indicated as primary or secondary values. Active power and reactive power are indicated as primary values.

User can monitor the following output and status on the LCD and at local/remote PCs.

- Relay element output
- Binary input/output
- CB status

■ Event Record

The most recent 96 time-tagged events are stored with 1 ms resolution.

Events recorded are as follows.

- Tripping and reclosing
- Alarms
- Change of binary input signal
- Change of relay setting Relay failure

■ Fault Record

A relay trip initiates fault recording. Time-tagged fault data can be stored for the 8 most recent faults. Fault record items are as follows.

- Date and time
- Faulted phase
- Phases tripped
- Tripping mode
- Fault location
- Pre-fault and post-fault current and voltage data (phase, phase to phase, symmetrical components)
- Autoreclose operation

■ Fault Location

Fault location is initiated by relay tripping signals excluding breaker failure, over current backup and out-of-step tripping. It can also be started on receipt of a start signal from external relays.

Fault location is indicated in km and % for the whole length of the protected line. The result of the fault location is stored as fault record data.

■ Disturbance Record

The relay can record 8 analog and 32 binary signals. The disturbance recorder is initiated by operation of the over current element, under voltage element and/or relay tripping.

In respect to analog data, phase voltage and current, residual voltage and current, and the residual current of the parallel line are recorded.

Pre-fault recording time is fixed at 300ms, post-fault recording time can be set from 100ms to 3s. The maximum number of stored records depends on the post-fault recording time. In the case of a post-fault recording time of 500ms, up to 20 disturbance records can be stored. The record number of the recorded data is displayed on the LCD.

■ Calendar and Time

The calendar and time and provided for the time-tagging of recorded data. Synchronization with GPS (Global Positioning System) is achieved via the IIRIG-B port.

HUMAN INTERFACE

■ Relay Front Panel

The relay front panel incorporates the following human interfaces. Setting the relay and viewing stored data are possible using the Liquid Crystal Display (LCD) and operation keys.

- 40 characters, four line LCD with back light
- Eight Light Emitting Diodes (LED) including four that are configurable
- Operation keys
- RS232C port
- Monitoring jacks

Figure 10 shows the relay front panel.



▲ Fig. 10 Relay front panel

The following items can be displayed on the LCD.

- Setting
- Metering
- Event records
- Fault records
- The number of disturbance records
- Fault location
- Any failure message detected by the automatic supervision

For the sake of security of setting changes, password protection can be set using the setting menu on the LCD. After the password has been set, the password must be entered to access the setting menu from a local or remote PC as well as on the LCD.

The contents of metering, fault records, and relay failures can be monitored by pressing the VIEW key. The VIEW key can be pressed without removing the relay front cover.

Arbitrary signals can be assigned to the four user configurable LEDs.

Two monitoring jacks are operable when the test mode is selected in the LCD window. An oscilloscope can be connected to the relay through these jacks. Selection of output signals on the monitoring jacks can be set from the menu.

■ Local PC

The user can communicate with the GRZ100 from a local PC via the RS232C port on the relay fascia. The following data can be viewed or analyzed on the local PC with RSM100 software.

- Setting
- Metering
- Event records
- Fault records
- Disturbance records
- Fault location

■ Remote Setting and Monitoring (RSM)

GRZ100 can be connected to the RSM system via the RS485 interface at the rear of the relay. The user can operate the relay from a remote PC in the same way as from a local PC.

A maximum of 32 relays can be connected to the remote PC in multi-drop mode, via the protocol converter (option).

The RSM100 software is also used to communicate with the relay and to view or analyze disturbance records on the remote PC.

The data transmission rate between relays and the protocol converter is 64kbps.

The relay is compliant with the transmission protocol defined by IEC 60870-5103.

Figure 11 shows the configuration of the RSM system.

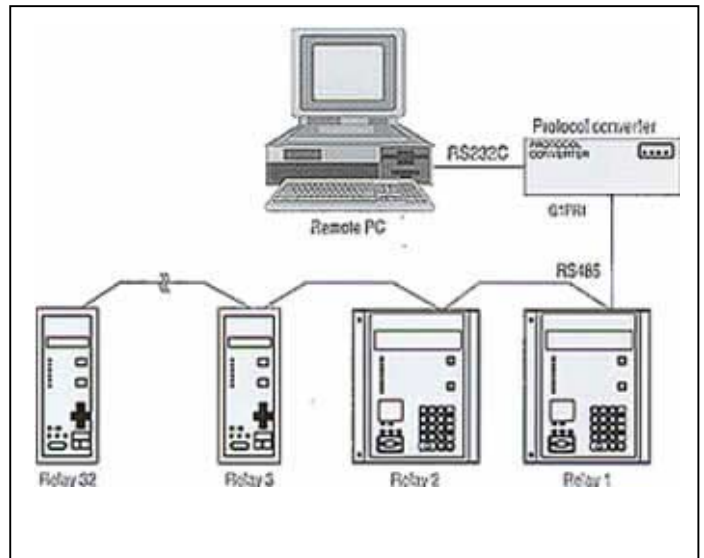

▲ Fig. 11 Remote setting and monitoring system

■ Relay Setting

The user can input or change settings using the operation keys on the relay fascia or via a local or remote PC with the RSM system. Password protection is provided to change settings.

Eight active setting groups are provided. This allows the user to set one group to normal conditions while other groups may be set to cover alternative operating conditions.

■ Configurable Binary Output Contacts

GRZ100 is provided with 12 to 40 user configurable normally open output contacts used for indication and alarm. The number of outputs varies according to the relay model.

■ Binary Inputs

GRZ100 is provided with 15 to 18 binary inputs. The number of inputs varies according to the relay model. The binary input circuits are provided with a logic level inversion function.

PC DISPLAY



▲ Metering



▲ Data analysis



▲ Event record



▲ Fault

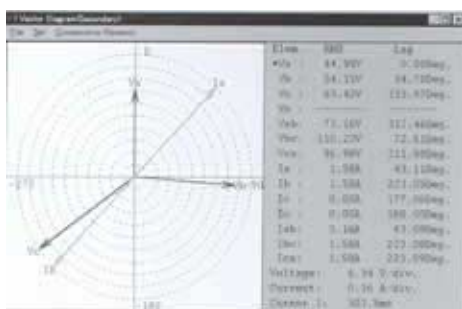

▲ Vector diagram

AUTOMATIC SUPERVISION

■ Automatic Monitoring Function

The automatic monitoring function will detect failures, should they occur, that might cause unwanted operation. The items monitored include the following:

- Analog input circuits
- Analog-to-Digital converter
- Watch Dog timer
- Binary output circuits
- DC power supply circuits
- CPU
- Signal channel circuits (for PUP, POP and UOP schemes)

■ Automatic Test Function

GRZ100 models equipped with a fault detector execute automatic tests for tripping output circuits. During automatic testing, the tripping circuit is automatically blocked.

In the BOP scheme, a signal check-back test function is provided to check the integrity of the signaling channels.

■ Alarms

In the unlikely event that a relay failure should occur, this is detected by automatic monitoring and the LED ALARM on the relay fascia is illuminated. A binary "RELAY FAILURE" output is simultaneously operated and the date/time of any such failure would be stored in the event record.

TECHNICAL DATA

■ Ratings

•AC current:	1 A or 5A
•AC voltage:	100V, 110V, 115V, 120V
•Frequency:	50Hz or 60Hz
•DC power supply:	110Vdc/125Vdc (Operative range: 88 to 150Vdc) 220Vdc/250Vdc (Operative range: 176 to 300Vdc) 48Vdc/54Vdc/60Vdc (Operative range: 38.4 to 72Vdc)
AC ripple on DC supply IEC 60255-11:	maximum 12%
DC supply interruption IEC 60255-11	Permissible duration of DC supply voltage interruption to maintain normal operation: less than 50ms at 110Vdc Restart time: less than 10s
•Binary input circuit DC voltage	110Vdc/125Vdc (Operative range: 88 to 150Vdc) 220Vdc/250Vdc (Operative range: 176 to 300Vdc) 48Vdc/54Vdc/60Vdc (Operative range: 38.4 to 72Vdc)

■ Overload rating

•AC current input:	4 times rated continuous 100 times rated for 1s
•AC voltage input:	2 times rated continuous 2.5 times rated for 1s

■ Burden

•AC Voltage circuit:	0.2VA per phase (at rated 5A) 0.4VA at zero sequence circuit (at rated 5A) 0.1VA per phase (at rated 1A) 0.3VA at zero sequence circuit (at rated 1 A)
•AC voltage circuit:	0.1VA (at rated voltage)
•DC power supply:	less than 15W (quiescent) maximum 25W (during operation)
•Binary input circuit:	0.5W/input at 110Vdc

■ CT ratio setting

• CT ratio:	1 to 20000 in 1 steps
-------------	-----------------------

■ Full scale of current for measurement

•Current:	65 times rated current
-----------	------------------------

■ Phase fault distance measuring element

Zone 1, Zone 2 and Zone 1 X:	0.1 to 250.0 ohms in 0.1-ohm steps (1 A relay) 0.01 to 50.00 ohms in 0.01-ohm steps (5A relay)
Z1S θ 1:	0° to 45° in 1° steps
Z1S θ 2:	45° to 90° in 1° steps
Zone 3 and Zone 4:	5 to 250 ohms in 1-ohm steps (1A relay) 1.0 to 50.0 ohms in 0.1-ohm steps (5A relay)
Characteristic angle:	45° to 90° in 1° steps
Zone 1 and Zone 4 offset:	7.5 ohms fixed (1A relay) 1.5 ohms fixed (5A relay)
Blinder (forward and reverse):	0.5 to 100.0 ohms in 0.1-ohm steps (1A relay) 0.10 to 20.00 ohms in 0.01-ohm steps (5A relay)
Characteristic angle (forward):	75° fixed
Characteristic angle (reverse):	90° to 135°

■ Earth fault distance measuring element

Zone 1, Zone 2 and Zone 1 X:	0.1 to 250.0 ohms in 0.1-ohm steps (1A relay) 0.01 to 50.00 ohms in 0.01-ohm steps (5A relay)
Z1G θ 1:	0° to 45° in 1° steps
Z1G θ 2:	45° to 90° in 1° steps

Zone 3 and Zone 4:	5 to 500 ohms in 1-ohm steps (1A relay) 1.0 to 100.0 ohms in 0.1-ohm steps (5A relay)
Characteristic angle:	45° to 90° in 1° steps
Blinder (forward and reverse):	0.5 to 100.0 ohms in 0.1-ohm steps (1A relay) 0.10 to 20.00 ohms in 0.01-ohm steps (5A relay)
Characteristic angle (forward):	75° fixed
Characteristic angle (reverse):	90° to 135°
Time settings of Zone 1, Zone 2, Zone 3, and Zone 4:	0.00 to 10.00s in 0.01s steps

■ Command protection

Coordination time for BOP: 0 to 50ms in 1 ms step

■ Operating and resetting time of distance measuring element

•Typical operating time:	20ms
•Operating time curve (SIR curve):	Refer to Figure 12
•Resetting time:	less than 90ms (for tripping output) less than 40ms (for signal output)

■ Accuracy of distance measuring element

•Static accuracy:	$\pm 5\%$ under SIR < 30 $\pm 10\%$ under 30 < SIR < 50
•Static angle accuracy:	$\pm 5^\circ$
•Transient overreach:	+5 -%

■ Minimum operating current

•Current:	0.08 A (1A relay) 0.4 A (5A relay)
-----------	---------------------------------------

■ Residual current compensation

Residual current compensation for reactance element of Zone 1, Zone 1X and Zones 2 are adjustable as follows.

•Earth return compensation:	0~1000% in 1% steps
•Mutual coupling compensation:	0~1000% in 1% steps

■ Phase selection element

•Undervoltage:	10 to 60V in 1 V steps
•Impedance:	0 to 250 ohms in 1-ohm steps (1A relay) 0.0 to 50.0 ohms in 0.01-ohm steps (5A relay)
•Characteristic angle:	45° to 90° in 1° steps
•Residual current compensation:	Automatically set according to line reactance settings

■ Switch-on-to-fault and Stub protection

•Overcurrent:	0.4 to 3.0A in 0.1A steps (1A relay) 2.0 to 15.0A in 0.1 A steps (5A relay)
---------------	--------------------------------------------------------------------------------

■ Voltage transformer failure supervision

•Undervoltage element (phase-to-phase):	50 to 100V in 1 V steps
•Undervoltage element (phase-to-earth):	10 to 60V in 1V steps
•Current change detection element:	0.1A fixed (1A relay) 0.5A fixed (5A relay)
•Residual voltage element:	20V fixed
•Residual current element:	Common use with earth fault over current element

■ Power swing blocking

•Detection zone:	2.5 to 75.0 ohms in 0.1-ohm steps (1A relay) 0.5 to 15.00 ohms in 0.01-ohm steps (1A relay)
•Current change detection element:	0.1 to 2.0 rated current in 01 step
•Detection time:	20 to 60ms in 1ms steps
•Resetting time:	500ms (Fixed)

■ Out-of-step protection

Resistive reach (OSTR1):	15 to 150 ohms in 1-ohm step (1A relay) 3.0 to 30.0 ohms in 0.1-ohm steps (5A relay)
Resistive reach (OSTR2):	5 to 50 ohms in 1-ohm steps (LA relay) 1.0 to 10.0 ohms in 0.1-ohm steps (5A relay)
Reactive reach (OSTXF):	5 to 250 ohms in 1-ohm steps (1A relay) 1.0 to 50.0 ohms in 0.1-ohm steps (5A relay)
Reactive reach (OSTXB):	1 to 50 ohms in 1-ohm steps (1A relay) 0.2 to 10.0 ohms in 0.1-ohm steps (5A relay)
Detection time (TOST):	0.01 to 1.00s in 0.1 steps

■ Breaker failure (BF) protection

Over current element:	0.1 to 2.0 times of current rating in 0.1 steps
•BE timer for re" trip of failed breaker:	50 to 500ms in 1 ms step
•BF timer for related breaker trip:	50 to 500ms, in 1 ms steps
•Operating time:	less than 20ms at darts less than 17ms at 60Hz
•Resetting time:	less than 15m, at darts less than 13ms at 60Hz

■ Inverse time over current protection

•Over current:	0.10 to 5.00 A in 0.01 (1A relay) 0.5 to 25.0A in 0.1A steps (5A relay)
•Time multiplier:	0.05 to 1.00 in 0.01 steps
•Characteristic:	Refer to Figure 7
•Accuracy of inverse time characteristics:	Standard Very and Long-time inverse: IEC 602553 class 5 Extremely inverse: IEC 60255-3 class 7.5

■ Definite time over current protection

•Over current:	0.10 to 2.00A in 0.01A steps (1A relay) 0.5 to 100.0A in 0.1 A steps (5A relay)
•Time for delayed trip:	0.00 to 10.00s in 0.01s steps
•Operating time:	less than 20ms
•Accuracy of pickup value:	±5%

■ Directional earth fault protection

•Characteristic angle:	0° to 90° in 1° steps (310 lags for 3V0)
•Polarizing voltage (3V0):	1.7 to 21.0V in 0.1 V steps
•Zero sequence current (3I0):	0.10 to 1.00A in 0.01A steps (1A relay) 0.5 to 5.0A in 0.1A steps (5A relay)
•Time for back trip:	0.00 to 10.00s in 0.01, top,
•Coordination time:	0 to 10 spurs in 1ms step
•Pickup time:	0 to 300ms in 10ms steps
• Accuracy of pickup value	±5%

■ Directional earth fault command protection

• Time for delayed trip:	0.00 to 0.30 in 0.01s steps
--------------------------	-----------------------------

■ Inverse time over current earth fault protection

•Overcurrent:	0.10 to 1.00A in 0.01A steps (1A relay) 0.5 to 5.0A in 0.1A steps (SA relay)
•Time multiplier:	0.05 to 1.00 in 0.01 steps
•Characteristic:	Refer to Figure 7
•Accuracy of inverse time characteristics:	Standard, Very and Long-time inverse IEC 60255-3 class 5 Extremely inverse: IEC 60255-3class7.5

■ Definite time over current earth fault protection

•Overcurrent:	0.10 to 1.00A in 0.01A steps (1A relay) 0.5 to 5.0A in 0.1A steps (5A relay)
•Pickup time:	0.00 to 10.00s in 0.01s steps
•Accuracy of pickup value:	±5%

■ Weak in feed and echo protection

•UV goose to-phase) element:	50 to 100 in 1V steps
•UV (phase- to earth) element:	10 to 60V in 1V steps

■ Autoreclose function

Number of shots: 1 to 4 shots

Timer settings

•Dead time for single-phase autoreclose:	0.01 to 10.00s in 0.01s steps
•Dead time for three-phase autoreclose:	0.01 to 100.00s in 0.01s steps
•Multi-shot dead line time:	5.0 to 300.0s in 0.1s steps
•Multi-shot reset time:	5.0 to 300.0s in 0.1s steps
•Ream time:	5 to 300s in 1s steps
•Pulse width of reclosing signal output:	0.1 to 10.0s in 0.1s steps
•Autoreclose reset time:	0.01 to 100.00s in 0.01s steps
•Reset time for developing fault:	0.01 to 10.00s in 0.01s steps

■ One-and-a-half breaker scheme

•Follower breaker autoreclose delay time: 0.1 to 10.0s in 0.1s steps

■ Voltage and synchronism check element

•Synchronism check angle:	5° to 75° in 1° steps
•UV element:	60 to 150V in 1 V steps
•OV element:	10 to 100V in 1 V steps
•Busbar or line dead check:	10 to 100V in 1 V steps
•Bus bar or line live check::	10 to 100V in 1 V steps
•Synchronism check time:	0.01 to 10.00s in 0.01s steps
•Voltage check time:	0.01 to 1.00s in 0.01s steps
•Operating time of synchronism check element:	less than 50ms
•Operating time of UV and OV element:	less than 40ms

■ Fault detector settings

•Multi-step over current element:	L1:0.10A, L2:0.16A, L3 0.26A, L4: 0.41A, L5:0.66A, L6: 1.05A, L7:1.68A(1A relay) L1: 0.50A, L2: 0.80A, L3:1.28A, L4: 205A, L5: 3.28A, L6: 5.24A, L7:8.39A (5A relay)
•Current change detection element:	10% of rated current
•Earth fault over current element:	10%, 15%, or 20% of rated current
•Undercharge element for earth fault:	46V
•Undervoltage element for phase fault:	80V
•Undervoltage change education element:	7 % of prefault voltage

■ Fault locator

- Line reactance and resistance settings: 0.0 to 999.9 ohms in 0.1-ohm steps (1 A relay)
0.00 to 199.99 ohms in 0.01-ohm steps (5A relay)
- Line lengths: 0.0 to 399.9km in 0.1 km steps
- Correction factor of impedance between lines: 80 to 120% in 1% steps
- Correction factor of impedance in each phase: 80 to 120% in 1% steps
- Accuracy: $\pm 2.5\text{km}$ (up to 100k)
 $\pm 2.5\%$ (up to 399.9km)
- Minimum measuring cycles: 2.5 cycles

■ Disturbance record initiation

- Over current element: 0.1 to 50.OA in 0.1A steps (1A relay)
0.5 to 250.OA in 0.1A steps (5A relay)
- Undervoltage element: 0 to 132V in 1 V steps (for phase fault)
0 to 76V in 1 V steps (for earth fault)
- Pre-fault time: 0.3s (fixed)
- Post-fault time: 0.1 to 3s

■ Communication port

Front communication port (local PC)

- Connection: Point to point
- Cable type: Multi-core (straight)
- Cable length: 15m (max.)
- Connector: RS232C 9-way D-type female

Rear communication port (remote PC)

- Signal level: RS485
- Transmission data rate for RSM system: 64kbps
- Connection: Multidrop mode (max. 32 relays)
- Connector: Screw terminals
- Cable and length: Twisted-pair cable, max. 1200m
- Isolation: 2kVac for 1 min.
- Transmission data rate for protocol IEC 60870-5-103: 9.6, 19.2kbps
- Interface to optional fibre can be provided for IEC60870-5-103.
- Connector type: ST type

■ IRIG-B port

- Connection: BNC connector
- Cable type: 50 ohm coaxial cable

■ Atmospheric environment

- Temperature (IEC60255-6):
- Operation guarantee: -10°C to $+55^{\circ}\text{C}$
- Storage: -20°C to $+70^{\circ}\text{C}$
- Humidity (IEC60068-2-3): 4 days at 93%, and 40°C

■ Binary inputs

- Minimum operating voltage: 70Vdc at 110Vdc/125Vdc rating

■ Contact ratings

Trip contacts

- Make and carry: 5A continuously
- Make and carry: 30A, 290Vdc for 0.5s (L/R=10ms)
- Break: 0.15A, 290Vdc (L/R=40ms)

Auxiliary contacts:

- Make and carry: 4A continuously
- Make and carry: 20A, 290Vdc for 0.5s (L/R \geq 5ms)

- Break: 0.1 A, 290Vdc (L/R=40ms)

Durability

- Loaded contact: 10,000 operations minimum
- Unloaded contact: 100,000 operations minimum

■ Internal battery

- Battery voltage: 3.6V
- Battery life: more than 5 years
- With auxiliary supply removed: 1 year

■ Mechanical design

- Weight: 10kg (Type-A), 13kg (Type-B)
- Case color: Munsell No. 10YR8/0.5
- Isolation: IP51
- Installation: Flush mounting or rack mounting

■ Vibration test

The relay withstands vibration in the frequency range of 10 to 150Hz with a sweep rate of 1 octave per minute in accordance with IEC Standard 60255-21-1, Class 1.

■ Shock and bump test

The relay withstands the shocks and bumps specified in IEC Standard 60255-21-2, Class 1.

■ Seismic test

The relay withstands the seismic specified in IEC Standard 60255-21-3, Class 1.

■ Dielectric test

The relay withstands 2kV at 50 or 60Hz for 1. minute between all circuits and the case, and between all separate circuits in accordance with IEC Standard 60255-4.

The relay withstands 1 kV at 50 or 60Hz for 1 minute across the open contacts in accordance with ANSI/IEEE C37.90.

■ Impulse voltage test

The relay withstands 5kV peak and 1.2/50us, 0.5 J waveform applied both transversely and between relay terminals and earth in accordance with IEC Standard 60255-5.

■ 1MHz burst disturbance test

The relay withstands 1 MHz, for 2s with 2.5kHz, 2.5kV attenuated to half in 3 to 6 cycles between independent circuits and independent circuits and case earth, and 1.0kV across terminals of the same circuit in accordance with IEC Standard 60255-22-1, Class 3.

■ Radiated electromagnetic field disturbance test

The relay withstands 25 to 1,000MHz, 10V/m radiated field in accordance with IEC Standard 60255-22-3, Class 3.

■ Electrostatic discharge test

The relay withstands the following magnitudes of electrostatic discharge in accordance with IEC Standard 60255-22-2.

- Contact discharge: 6kV, Class 3
- Air discharge: 15kV, Class 4

■ Fast transient disturbance test

The relay withstands 4kV $\pm 10\%$. 2.5kHz applied in common mode, at least 1 minute in accordance with IEC Standard 60255-22-4, Class 4.

■ Surge immunity

The relay withstands 4kV peak and 1.2/50ms between all groups and case earth, and 2kV peak and 1.2/50ms between terminals of each group in accordance with IEC Standard 61000-4-5, Level 4.

■ EMC compliance

Conformity to 89/336/EEC, generic standards EN50081-2, EN50082-2
Product safety, conformity to 73/23/EEC, generic safety standards EN61010-1, EN60950

■ Current transformer requirements

To maintain the proper operation of the distance relay, the CT should have a minimum knee-point voltage V_k given by:

For Class X

- The CT should have a minimum knee-point voltage V_k given by:

$$V_k = I_f \cdot \{1 + X/R\} \cdot (R_{CT} + R_L + Z_R)$$

where,

V_k : Knee-point voltage of the CT, which is defined as the point in the magnetizing characteristic at which a 10% increase in voltage (V) produces a 50% increase in magnetizing current

X/R : Primary system reactance to resistance ratio

I_f : The secondary equivalent of the maximum AC fault current for a zone 1 fault

RCT: Resistance of the CT secondary winding in ohms

RL: Resistance of secondary leads in ohms

ZR: Resistance of the relay current circuit in ohms per phase

For IEC Class 5P

$$[(V_A - ALF)/I_n] + (R_{CT} \cdot ALF \cdot I_n) > I_f \cdot (1 + X/R)(Z_R + R_{CT} + R_L)$$

where,

V_A : CT burden

ALF: Accuracy limit factor

■ Protocol converter (Option)

•Type:	G1PR1
•AC power supply	
Voltage:	100/110V
Frequency:	50 or 60Hz
Burden:	less than 20W
•Transmission data rate	
PC side (RS232C):	9.6, 19.2, 38.4kbps
Relay side (RS485):	64kbps
•Size:	320(W) x 142.5(H) x 430(D)
•Weight:	7kg

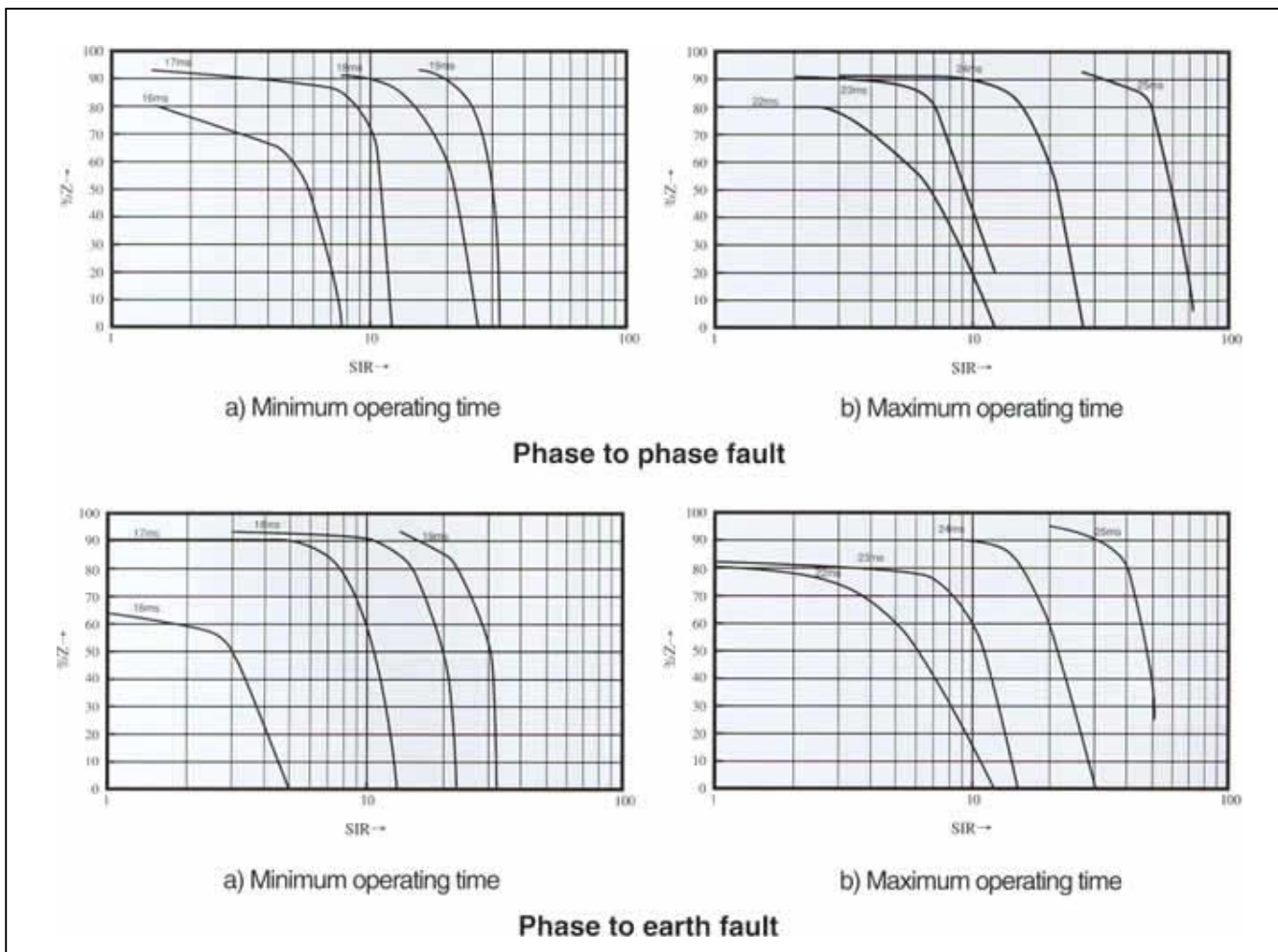
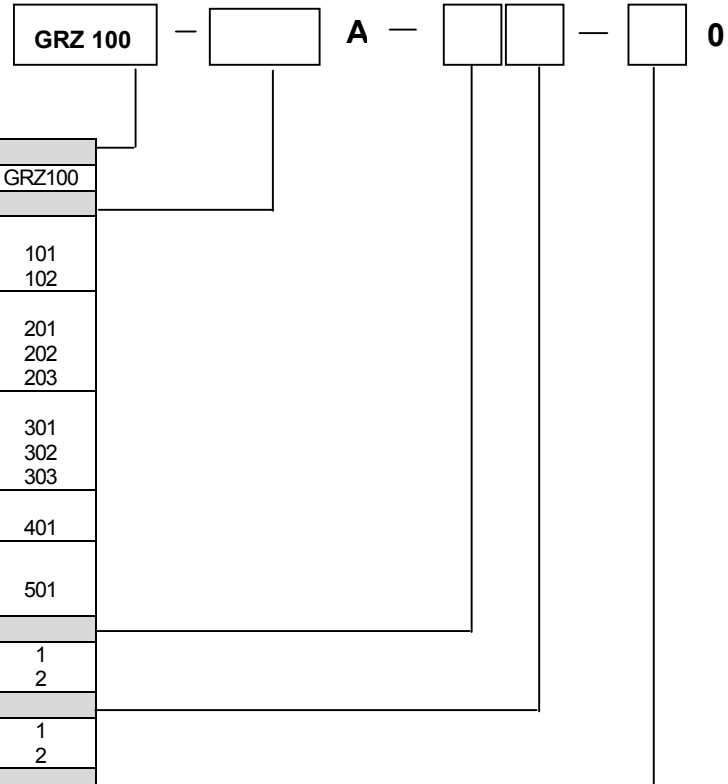

Fig. 12 Operating time curve

ORDERING

1. Distance Relay



Relay Type:	
Distance relay	GRZ100
Relay Model:	
-Model 100: No autoreclose / No fault detector 12 N/O configurable output contacts 22 N/O configurable output contacts	101 102
-Model 200: With autoreclose for single breaker scheme / No fault detector 22 N/O configurable output contacts 26 N/O configurable output contacts 40 N/O configurable output contacts	201 202 203
-Model 300: With autoreclose for one and a half breaker scheme / No fault detector 22 N/O configurable output contacts 26 N/O configurable output contacts 40 N/O configurable output contacts	301 302 303
-Model 400: With autoreclose for single breaker scheme / with fault detector 34 N/O configurable output contacts	401
-Model 500: With autoreclose for one and a half breaker scheme / with fault detector 34 N/O configurable output contacts	501
CT rating:	
1A	1
5A	2
Frequency:	
50Hz	1
60Hz	2
DC power supply rating:	
110V/125V	1
220V/250V	2
48V	3

Note:
Please inform us which is ordered panel surface mount type or 19-inch rack mount type. In 19 inch rack mount type, please order attachment kit.
-for relay case Type-A attachment kit: EP101
-for relay case Type-B attachment kit: EP102

2. Protocol Converter (option)

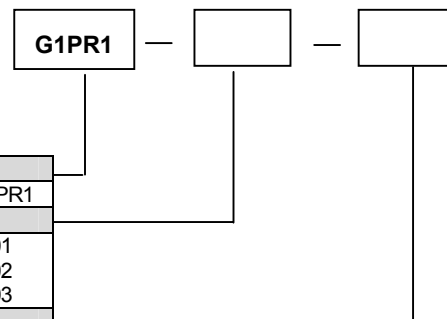

Type:	
Protocol converter	G1PR1
Model:	
Not provided for external time synchronization	01
Provided with external time synchronization (IRIG-B)	02
Provided with external time synchronization (IRIG-B and GPS)	03
AC power supply rating:	
AC 100/110V	10

EXTERNAL CONNECTION

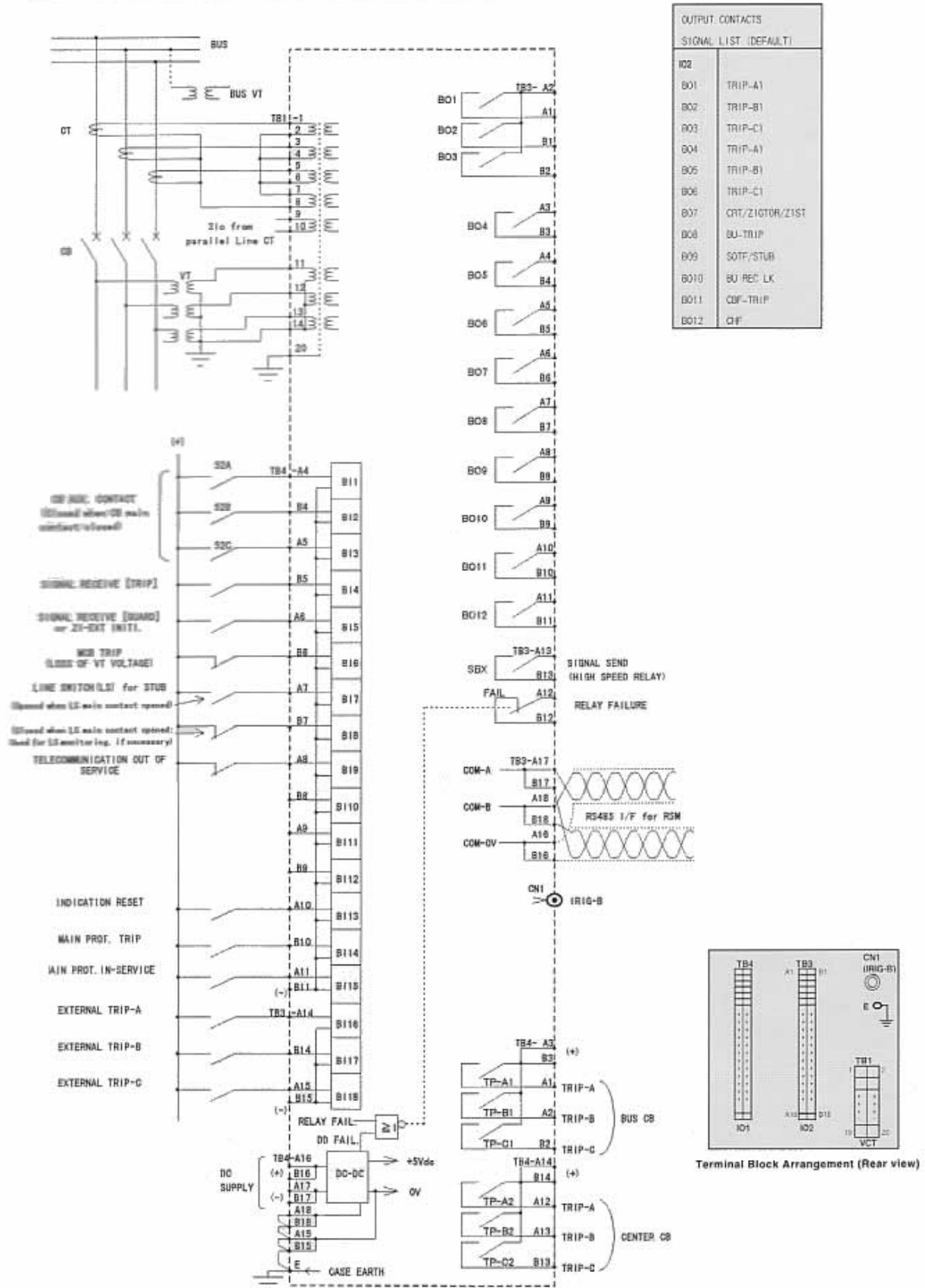

Fig. 13 External connection of Model 101

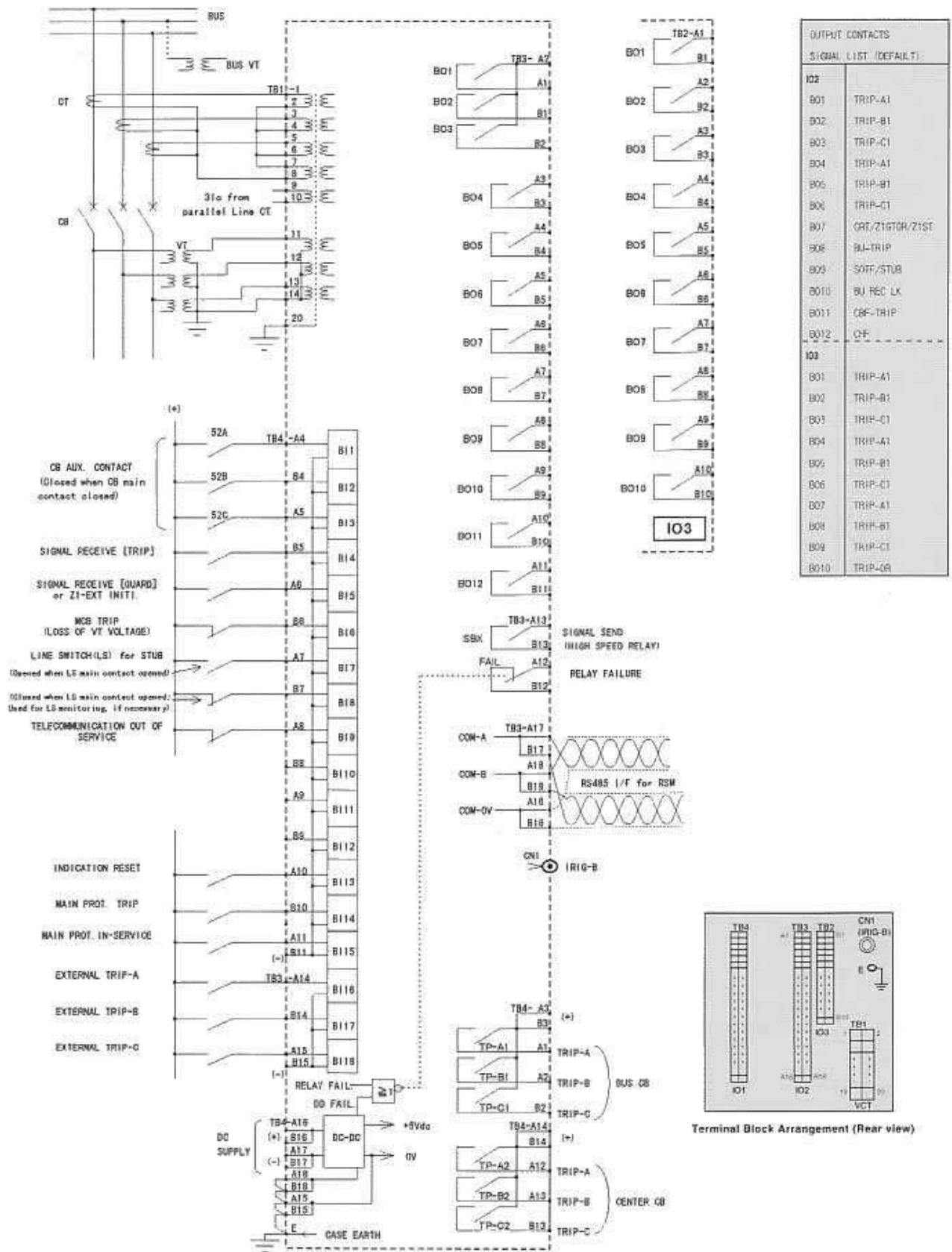

Fig. 14 External connection of Model 102

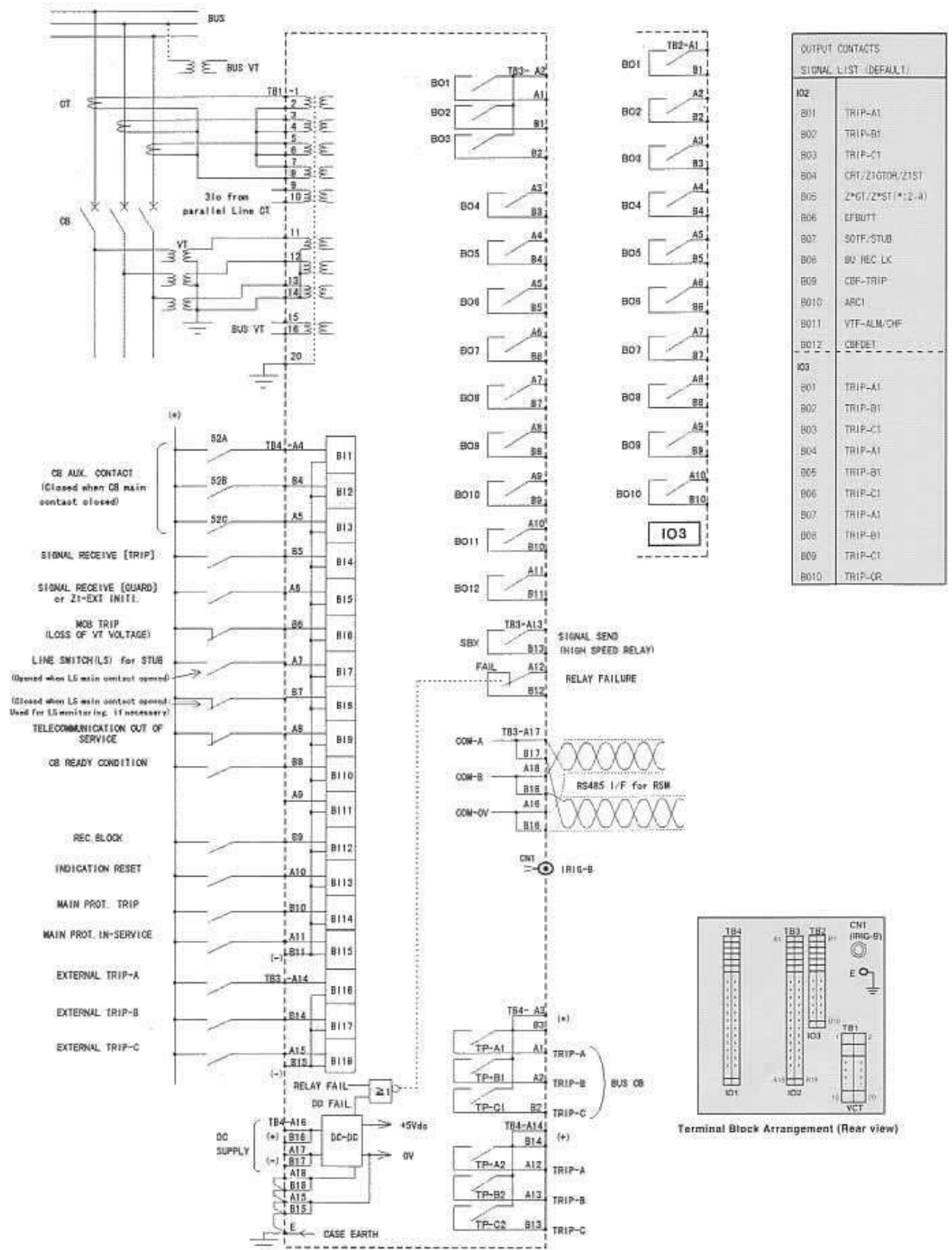
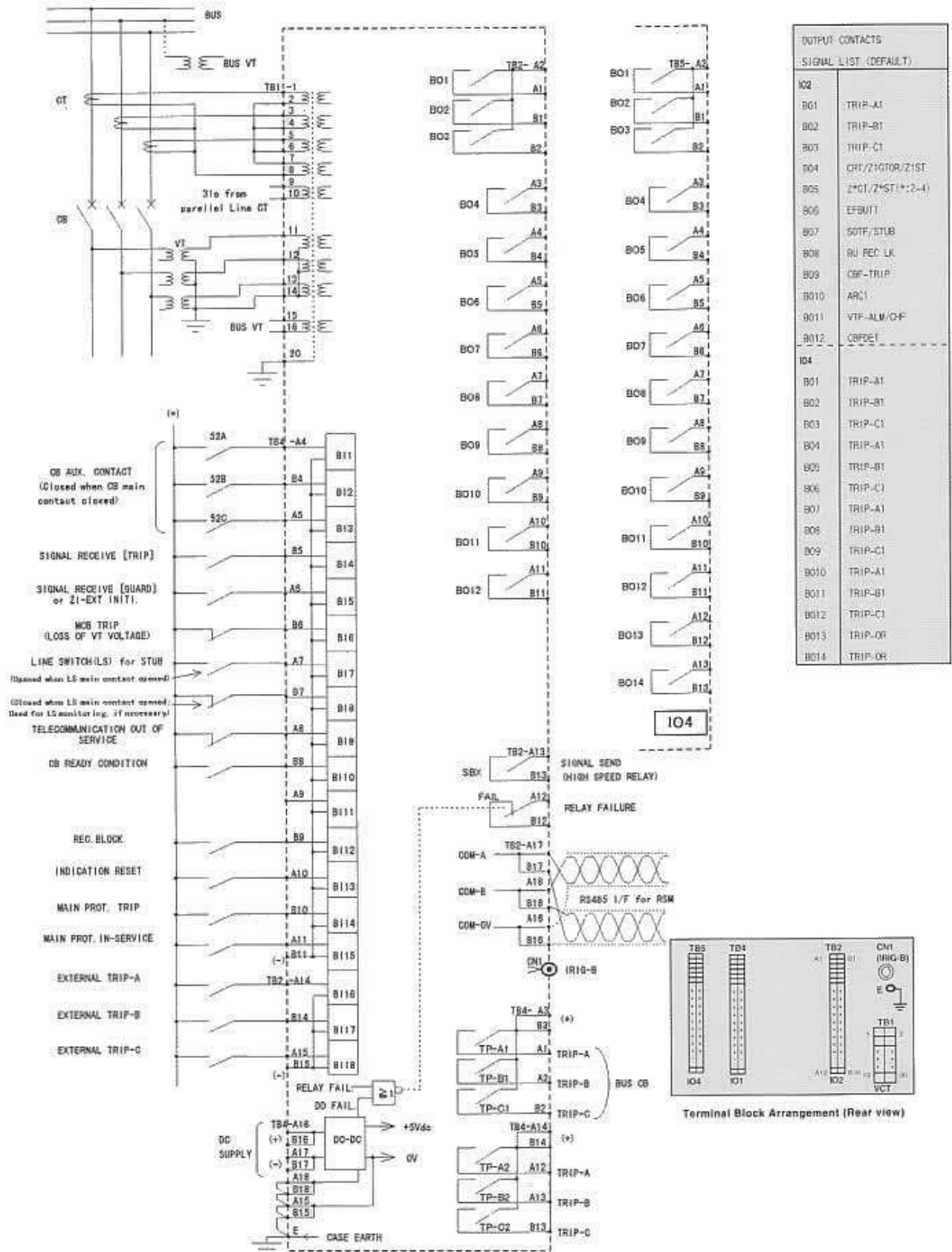

Fig. 15 External connection of Model 201



OUTPUT CONTACTS	
SIGNAL LIST (DEFAULT)	
BO1	TRIP-A1
BO2	TRIP-B1
BO3	TRIP-C1
BO4	CR1/Z1GTOR/Z1ST
BO5	Z*CT/Z*ST(+;2-4)
BO6	EFBUT
BO7	SOFF/STUB
BO8	BU REC LK
BO9	CBF-TRIP
BO10	ARC1
BO11	VTF-ALM/CF
BO12	CBFDET
<hr/>	
IO4	TRIP-A1
BO2	TRIP-B1
BO3	TRIP-C1
BO4	TRIP-A1
BO5	TRIP-B1
BO6	TRIP-C1
BO7	TRIP-A1
BO8	TRIP-B1
BO9	TRIP-C1
BO10	TRIP-A1
BO11	TRIP-B1
BO12	TRIP-C1
BO13	TRIP-OR
BO14	TRIP-OR

Fig. 16 External connection of Model 202

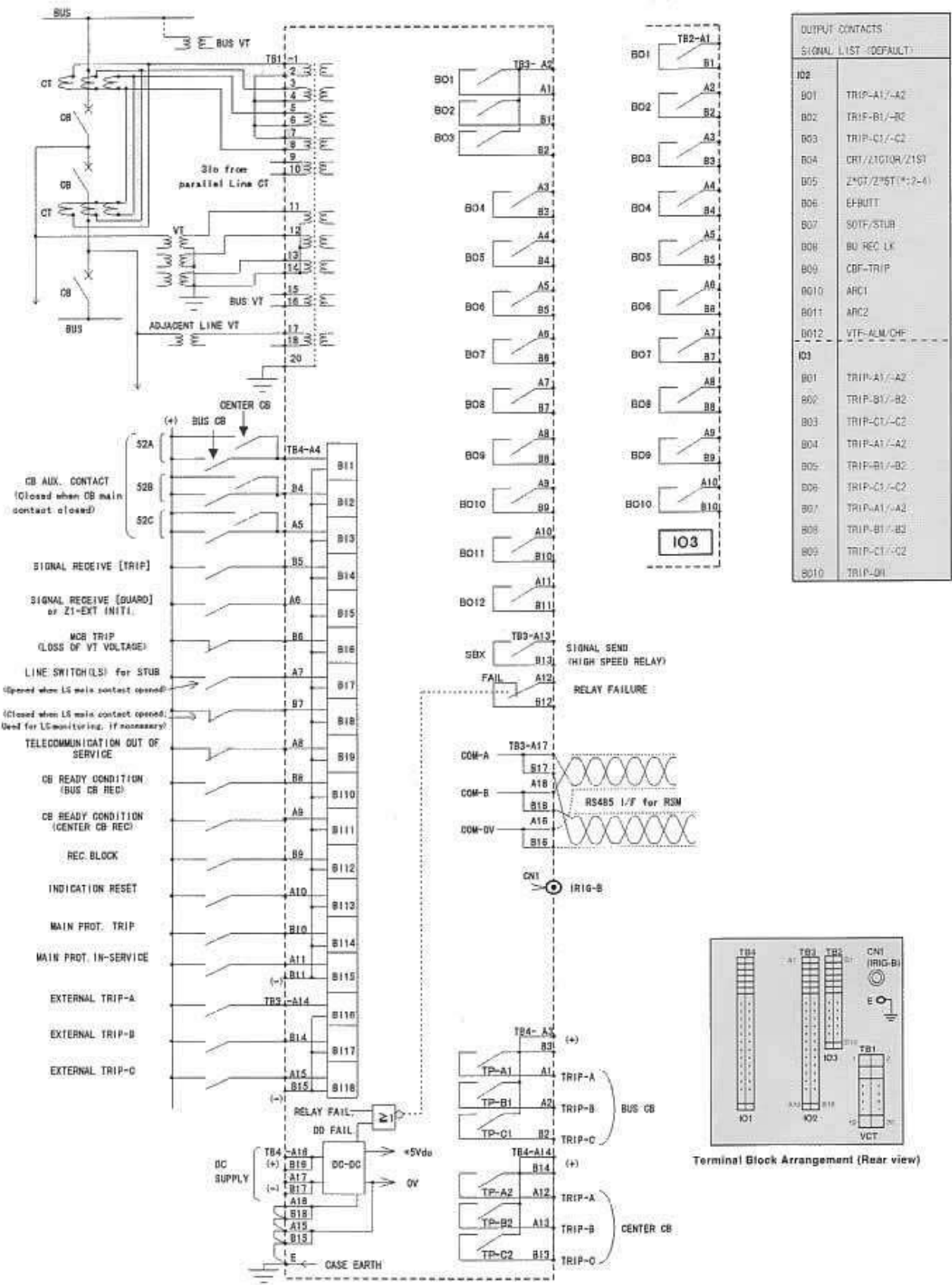

Fig. 18 External connection of Model 301

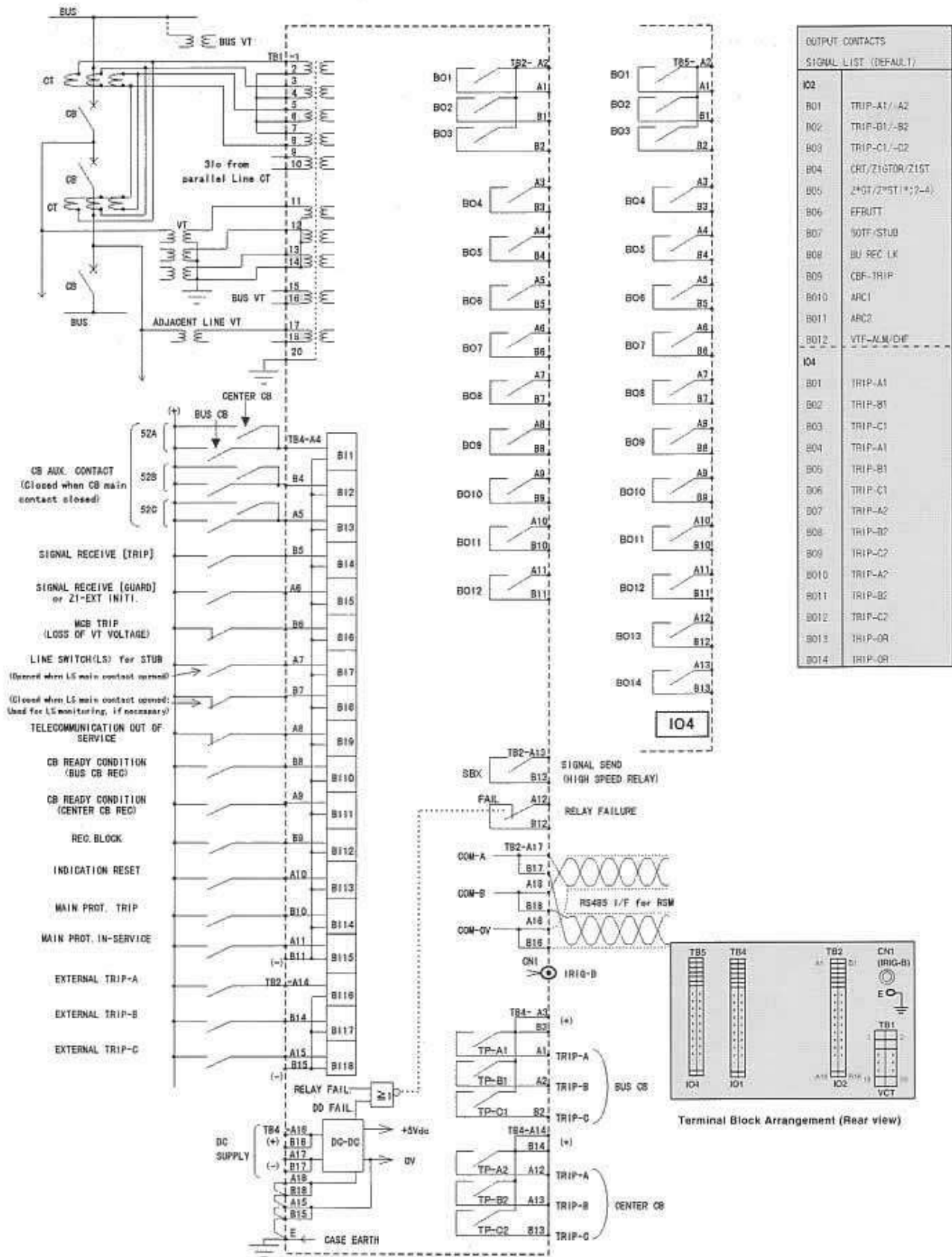

Fig. 19 External connection of Model 302

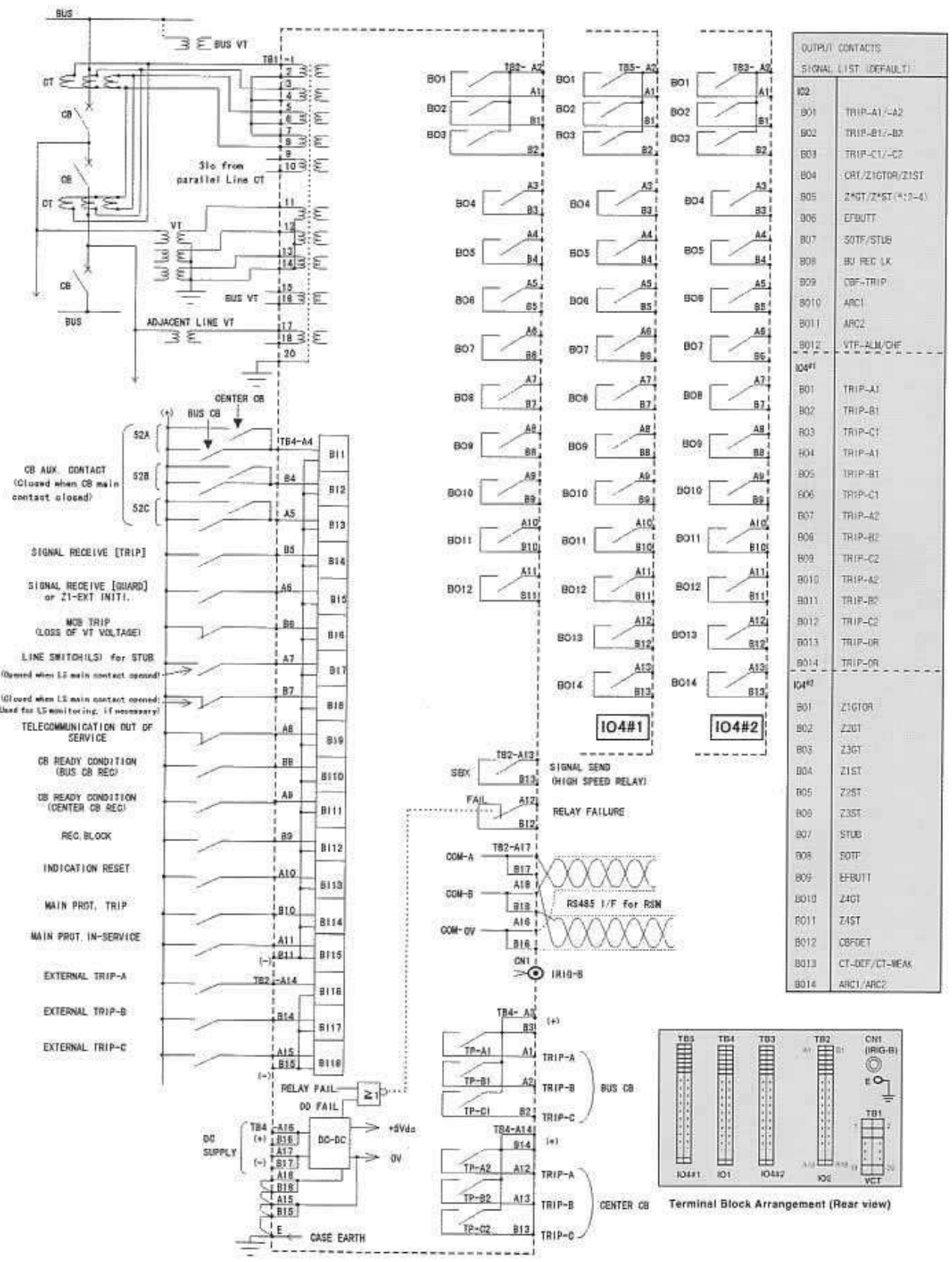

Fig. 20 External connection of Model 303

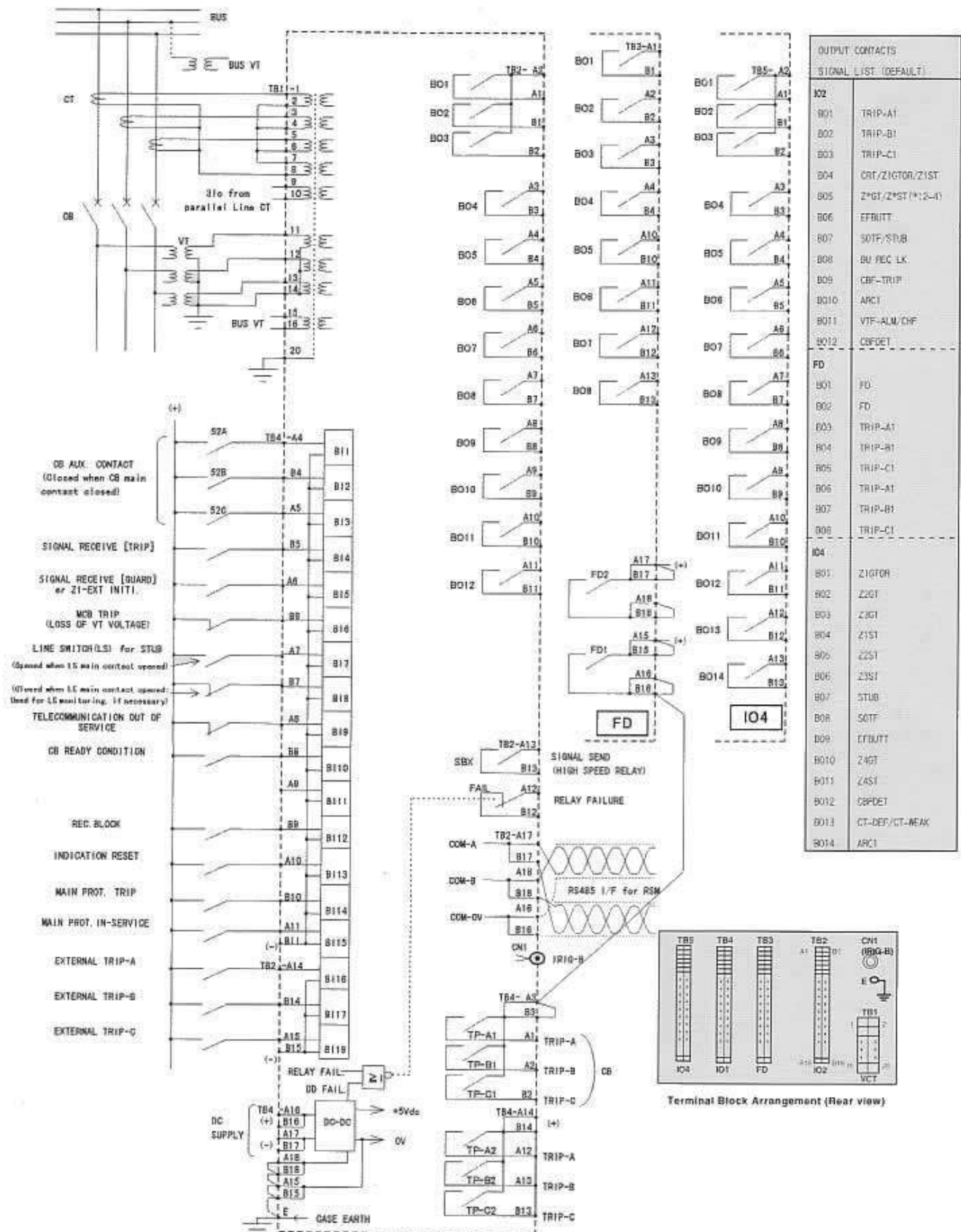

Fig. 21 External connection of Model 401

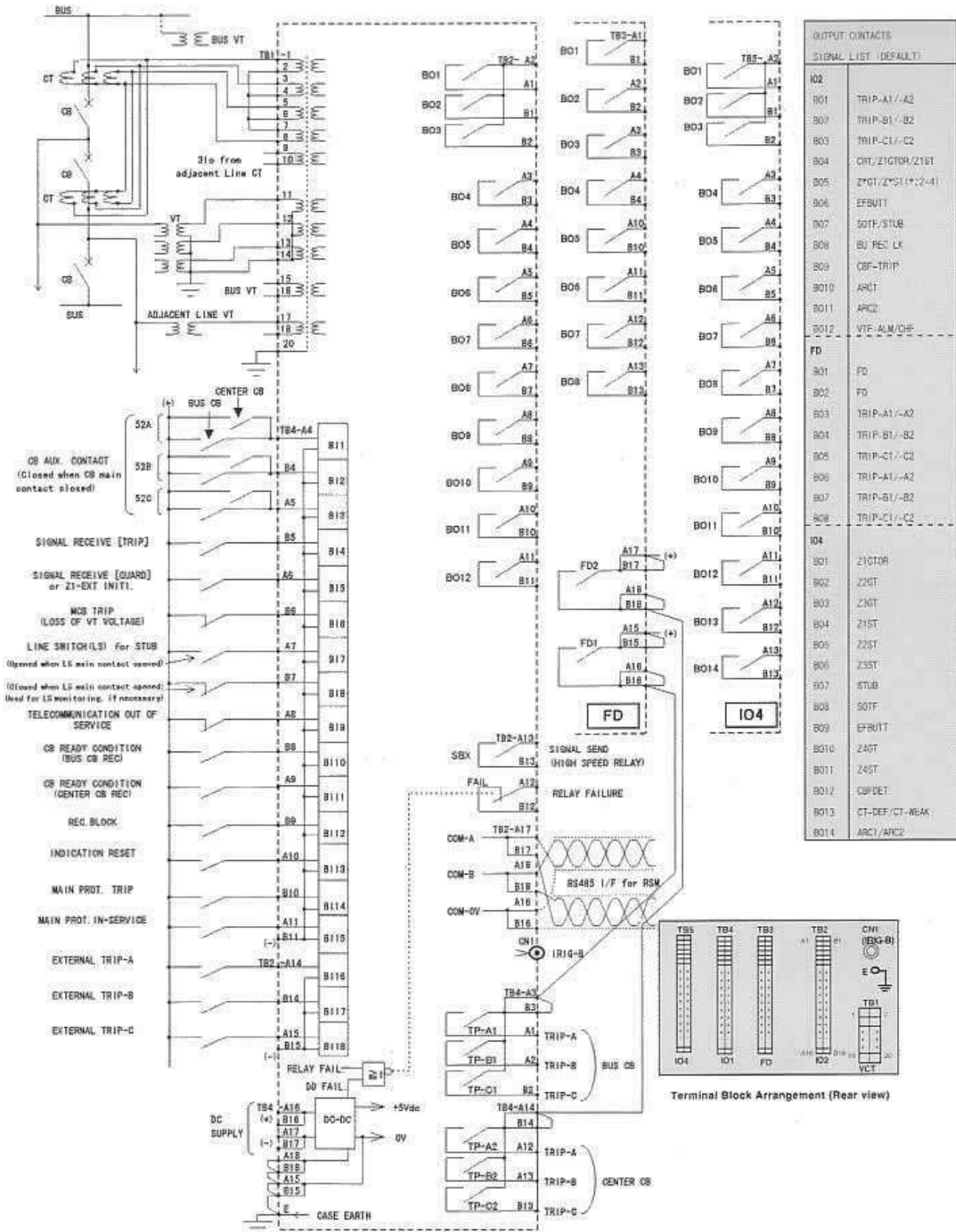

Fig. 22 External connection of Model 501

RELAY OUTLINE

Panel Surface Mount

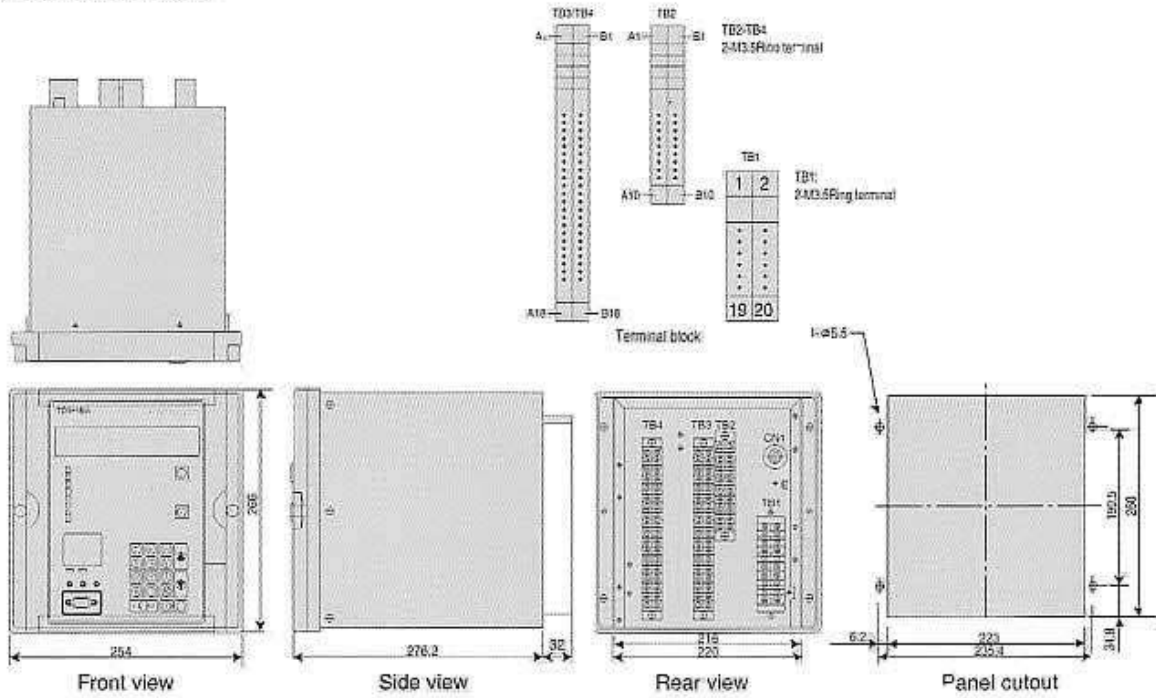

Fig. 23 Relay Case Type-A outline (for Model 101, 102, 201, 301)

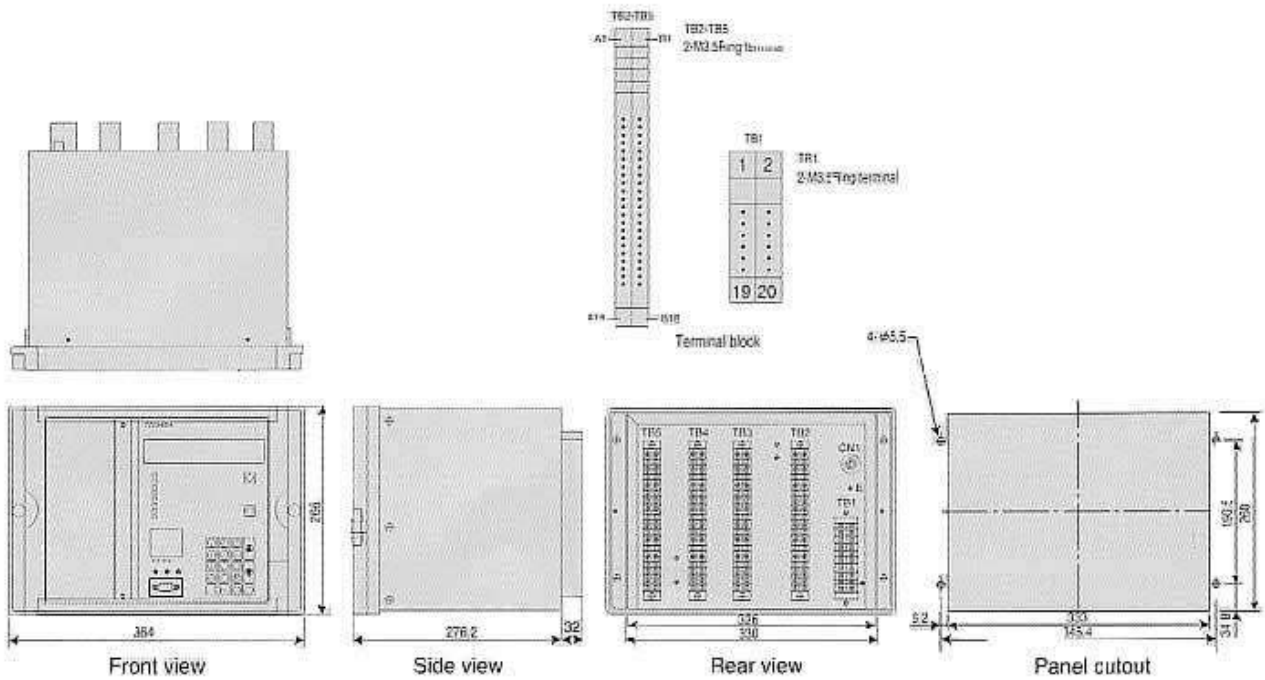

Fig. 24 Relay Case Type-B outline (for Model 101, 102, 201, 301)

19-inch Rack Mount

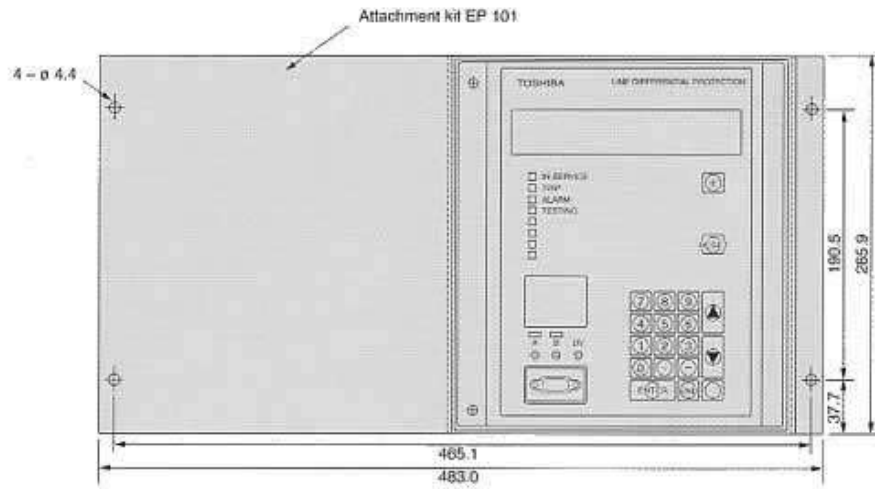

Fig. 25 Relay case Type-A outline (for Model 101, 102, 201, 301)

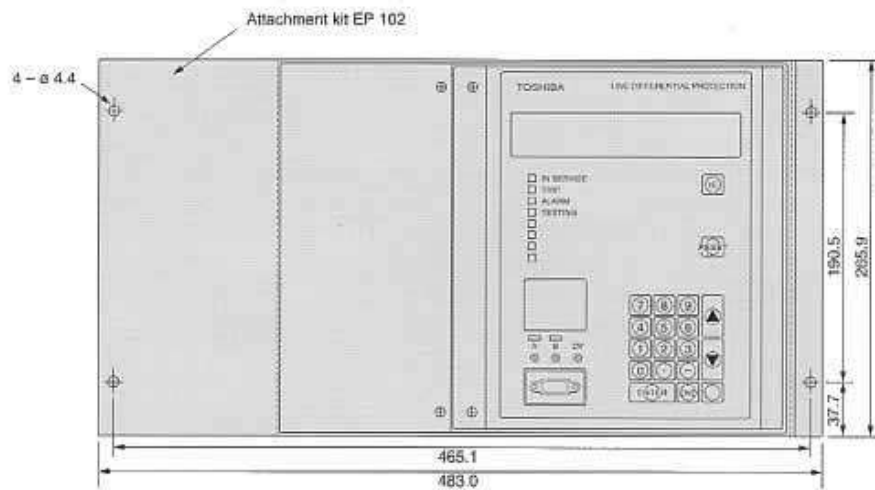

Fig. 26 Relay case Type-B outline (for Model 202, 203, 302, 303, 401, 501)

Outline of Protocol Converter

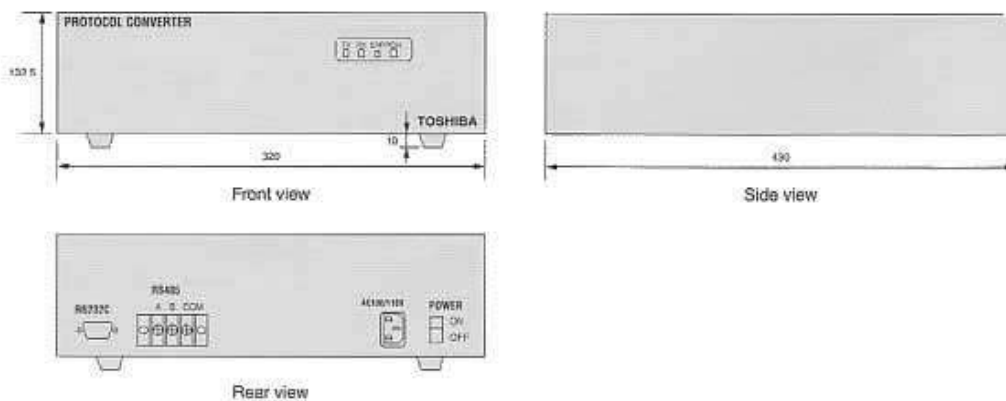
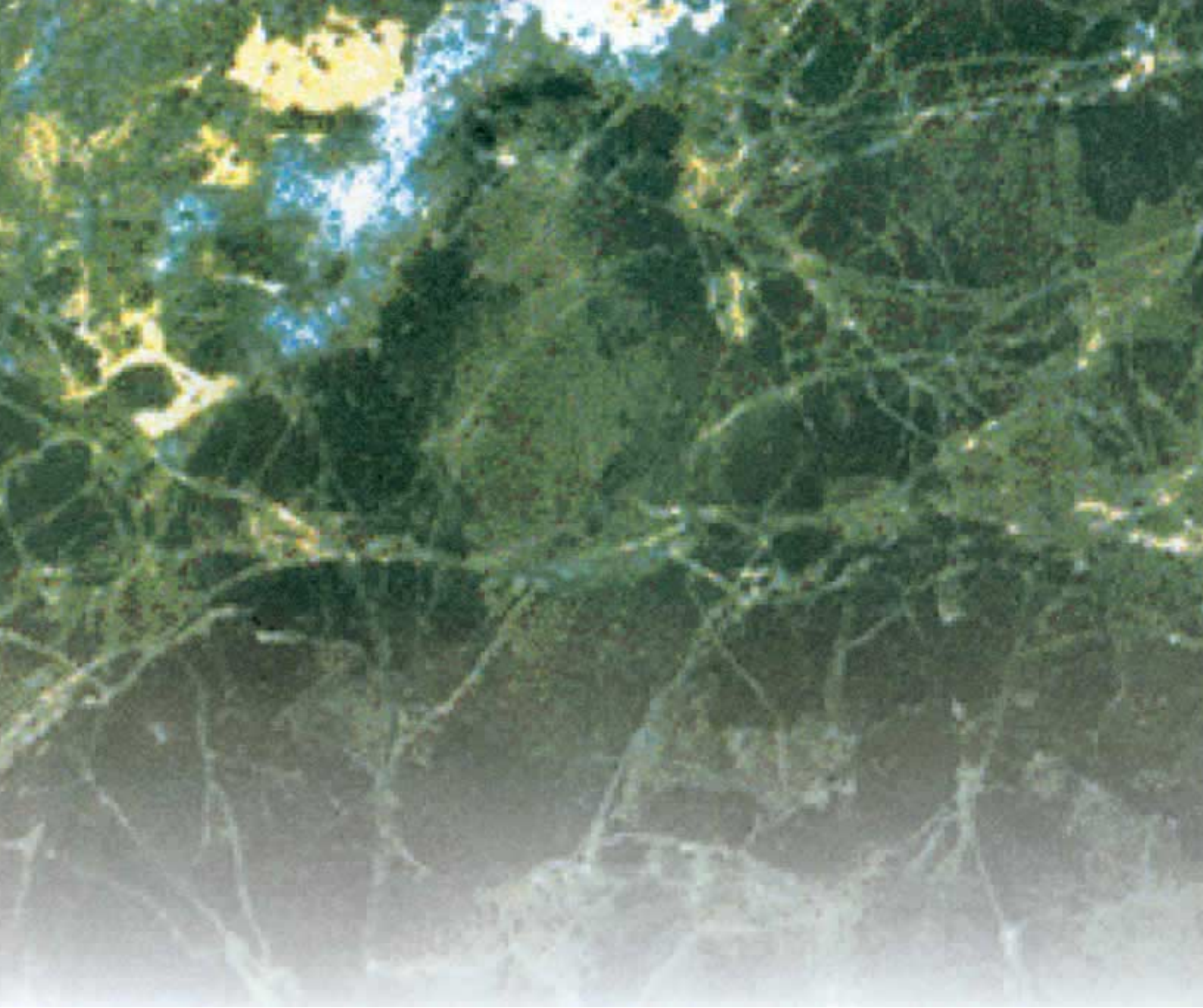

Fig. 27 Outline of protocol converter G1PR1

MEMO

MEMO



TOSHIBA CORPORATION

POWER SYSTEMS & SERVICES COMPANY

UTILITY POWER SYSTEMS ENGINEERING DEPT

1-1, SHIBAURA 1-CHOME, MINATO-KU, TOKYO 105-8001, Japan

PHONE: 03-3457-3631

FACSIMILE: 03-5444-9196

6322-4

'01-2 C1